



East County Fire and Rescue

600 NE 267th Avenue Camas, WA 98607

(360) 834-4908 (phone)

(360) 835-8920 (fax)

www.ecfr.us



Regular Board of Fire Commissioners Meeting December 19, 2023

Station 91

6:30 PM

Agenda



This meeting will be held in hybrid format, in-person and using Zoom video conferencing. The link and telephone dial-in number are provided below:

Video Conferencing Link: <https://us02web.zoom.us/j/88935636591>

Dial-In Telephone Number: (253) 215-8782

Meeting ID 889 3563 6591 and Passcode 899861

This meeting is being recorded, please silence or turn off your personal cell phones, pagers, etc.

Call to Order

Flag Salute

Agenda Adjustments

Consent Agenda

- Approval of December 05, 2023 Regular Board Meeting Minutes.
- Approval of December 05, 2023 Local BVFF&RO Meeting Minutes.
- Approval of December 06, 2023 Strategic Planning Meeting Minutes.
- Approval of Financial Transactions.
- Excuse absent Commissioner(s).

Public Input

Correspondence

Staff Reports

1. Chief Hartin.
2. Assistant Chief Jacobs.
3. Volunteer Firefighters Association.
4. Safety Committee. – Minutes from last safety meeting are included in this packet.

Fire District Business

1. Resolution #337-12192023 – Surplus Equipment (Multiple items – See Attachment A).
2. Resolution #338-12192023 – Purchase of a type one fire engine to replace Apparatus 1014, currently in service as Engine 94.
3. Resolution #339-12192023 – Transfer funds from the general fund to the grants management fund to meet 5% match.

Committee Meetings:

1. Communication with Neighboring Elected Officials.
 - City of Camas, TBA.
 - City of Washougal, TBA.
2. Risk Group, January 3, 2024 at 8:00 AM.
3. East County Ambulance Advisory Board (ECAAB), TBA.
4. Safety Meeting, TBA.

Commissioner Comments

Public Comment

Local Board for Volunteer Firefighters and Reserve Officers

Upcoming Meetings

- Review of the district's monthly event calendar.
- Next Regular Board Meeting will be held January 2, 2024 Station 91 at 6:30 PM – hybrid format.
- Next Strategic Planning Meeting January 3, 2024 Station 91 at 3:00 PM – hybrid format.

Executive Session

RCW 42.30.110 (1) (g): To evaluate the qualifications of an applicant for public employment or to review the performance of a public employee.

Adjournment



East County Fire and Rescue

600 NE 267th Avenue Camas, WA 98607

(360) 834-4908 (phone)

(360) 835-8920 (fax)

www.ecfr.us



Board of Fire Commissioners Consent Agenda

December 19, 2023

1. Approval of minutes:
 - December 05, 2023 Regular Board Meeting Minutes.
 - December 05, 2023 BVFF Meeting Minutes.
 - December 06, 2023 Strategic Planning Meeting Minutes.
2. Invoices for \$21,585.25 check number 14930 through 14947 dated December 7, 2023.
3. Approved commissioner stipends for the period of December 1 through December 15 with a December 25, pay date.

Name	Regular Meeting	Committee Meeting	Special Meeting	Education	Other	Total
Hofmaster	1	0	1	0	0	2
Martin	1	0	1	0	0	2
Petty	1	0	1	0	0	2
Seeds	1	0	1	0	0	2
Taggart	1	0	1	0	0	2

4. Voided/Destroyed Claims/Payroll Warrants.
5. Payroll/Benefits/EFT's in the amount of \$59,892.34 (Payroll).

Martha Martin, Chairperson

Michael Taggart, Vice Chair

Sherry Petty, Commissioner

Steve Hofmaster, Commissioner

Joshua Seeds, Commissioner



East County Fire and Rescue

600 NE 267th Avenue Camas, WA 98607

(360) 834-4908 (phone)

(360) 835-8920 (fax)

www.ecfr.us



Regular Board of Fire Commissioners Meeting

December 05, 2023

Station 91

6:30 PM

Draft Minutes

Attendance

Martha Martin

Mike Taggart

Joshua Seeds

Steve Hofmaster

Sherry Petty

Chief Ed Hartin

Assistant Chief Jacobs

Pam Jensen

Jennifer

Cody Parry

Zach Allen

Cody Sorensen

Trevor Pedersen

Call to Order

Chairperson Martha Martin called the meeting to order at 18:31 via Hybrid Meeting. This meeting was conducted in hybrid in-person/video conference format.

Flag Salute

Commissioner Martin led the flag salute.

Agenda Adjustments

Consent Agenda

- Approval of November 21, 2023 Regular Board Meeting Minutes.
- Approval of November 21, 2023 Local BVFF&RO Meeting Minutes.
- Approval of Financial Transactions.
- Excuse absent Commissioner(s).

Motion by Commissioner Taggart to approve the consent agenda as amended, seconded by Commissioner Seeds. Motion passed unanimously.

Public Input

No comments.

Correspondence

None

Staff Reports

1. Chief Hartin did a presentation of the Challenge Coin to the Commissioners and staff in attendance.
2. Chief Hartin's report is in the meeting packet.
3. Assistant Chief Jacobs gave his report; a copy is in the meeting packet.
4. Assistant Chief Jacobs reported that the Volunteer Firefighter's Association had nothing new to report.
5. Assistant Chief Jacobs reported that per the safety committee there were no accidents/incidents since the last board meeting.

Fire District Business

1. FY2024 Board Assignments - **Motion by Commissioner Seeds to approve** FY2024 Board Assignments, **Seconded by Commissioner Taggart. Motion passed unanimously.**
2. FY2024 Observed Holidays - **Motion by Commissioner Taggart to approve** FY2024 Observed Holidays, **Seconded by Commissioner Hofmaster. Motion passed unanimously.**
3. Resolution #336-12052023 FY2024 Board Meeting Dates. The purpose of this resolution is to adopt the FY2024 Board Meeting Dates. **Motion by Commissioner Taggart to approve** Resolution #336-12052023 FY2024 Board Meeting Dates. **Seconded by Commissioner Hofmaster. Motion passed unanimously.**
4. Chief Hartin asked the Board to approve the purpose, scope and policy for:
 - 1.2.27 Reporting Improper Government Action & Whistleblower Protection.
 - 1.3.5 Asset Management.
 - 4.2.6 Command Function 6 – Organization.
 - 4.2.7 Command Function 7 – Review, Evaluate, and Revise.
 - 4.2.8 Command Function 8 – Continue, Support, and Terminate Command.**Motion by Commissioner Taggart to approve** the Purpose, Scope and Policy for SOG 1.2.27, 1.3.5, 4.2.6, 4.2.7 and SOG 4.2.8, **Seconded by Commissioner Seeds. Motion passed unanimously.**
5. Approve Fire Chief Employment Agreement Renewal as written. **Motion by Commissioner Seeds to approve** the Fire Chief Employment Agreement Renewal as written, **Seconded by Commissioner Taggart. Motion passed unanimously. (Commissioner Petty not present on zoom to vote).**

6. Diesel Exhaust Extraction Systems Bid Award – Chief Hartin went over the bid with the Board. He asked the board to approve the bid. **Motion by Commissioner Taggart to approve the Diesel Exhaust Extraction System Bid Award, Seconded by Commissioner Hofmaster. Motion passed unanimously. (Commissioner Petty not present on zoom to vote).**

Committee Meetings

1. Communication with neighboring elected officials.
 - City of Camas, TBA.
 - City of Washougal, TBA.
2. Risk Group, October 18, 2023 at 8:00 AM via Zoom.
3. Safety Meeting, January 25, 2024 at 7:30 PM at Station 91.
4. East County Ambulance Advisory Board (ECAAB), TBA.

Commissioners Comments

Commissioner Seeds discussed bipartisan infrastructure act and appropriate workforce. Discussion ensued.

Commissioner Seeds also said that he is not running for 2024 term for Clean water advisory Commissioner.

Commissioner Seeds discussed fluorinated foams, and that ECFR is in process of disposing the foam and that we are ahead of the curve. Discussion ensued.

Commissioner Martin shared that her and Commissioner Seeds need to do their Oath. If we can ask Greg Kimsey to come and swear them in on January 2, 2024 meeting. Discussion ensued.

Public Input

Local Board for Volunteer Firefighters and Reserve Officers

No new business.

Upcoming Meetings

- Review of the district's monthly event calendar.
- Regular board meeting will be December 19, 2023 Station 91 at 6:30 pm. – Hybrid format.
- Strategic planning workshop December 06, 2023 Station 91 at 2:00 pm. – Hybrid format.

Both the strategic planning workshop and regular board meeting will be in hybrid format permitting in-person or video conference participation. The link for video conference participation is provided on the district's website (www.ecfr.us).

Executive Session

Schedule an executive session for next regular board meeting to evaluate the performance of a public employee.

Adjournment

Motion by Commissioner Seeds to adjourn at 20:02, seconded by Commissioner Taggart. Motion passed unanimously. (Commissioner Petty not present on zoom to vote).

Martha Martin, Chairperson

Michael Taggart, Vice Chair

Sherry Petty, Commissioner

Steve Hofmaster, Commissioner

Joshua Seeds, Commissioner

Attest

Debbie Macias, District Secretary
Ed Hartin, Chief (Alternate)



East County Fire and Rescue

600 NE 267th Avenue Camas, WA 98607

(360) 834-4908 (phone)

(360) 835-8920 (fax)

www.ecfr.us



Local Board for Volunteer Fire Fighters & Reserve Officers Meeting December 05, 2023

Station 91
Draft Minutes

Attendance

Martha Martin

Sherry Petty

Assistant Chief Jacobs

Cody Parry

Trevor Pedersen

Mike Taggart

Steve Hofmaster

Pam Jensen

Zach Allen

Joshua Seeds

Chief Ed Hartin

Jennifer

Cody Sorensen

Call to Order

This meeting was conducted in hybrid in-person/video conference format.

Chairperson Martha Martin called the meeting to order at 20:01 via Hybrid Meeting.

Business

No new business.

Adjournment

The local board adjourned at 20:01.

Martha Martin, Chairperson
Commissioner Joshua Seeds, Alternate

Tad Crum, Firefighters Association Liaison

Robert Jacobs, Assistant Chief
Ed Hartin, Chief (Alternate)

Michael Taggart, Commissioner
Sherry Petty, Commissioner (Alternate)

Attest

Debbie Macias, District Secretary
Ed Hartin, Chief (Alternate)



East County Fire and Rescue

600 NE 267th Avenue Camas, WA 98607

(360) 834-4908 (phone)

(360) 835-8920 (fax)

www.ecfr.us



Special Board of Fire Commissioners Meeting

December 06, 2023

Station 91

3:00 PM

Draft Minutes

Attendance

Martha Martin

Mike Taggart

Joshua Seeds

Sherry Petty

Steve Hofmaster

Chief Ed Hartin

Debbie Macias

Pam Jensen

Ryan Grable

Call to Order

This meeting was in hybrid version in-person/video conference format.

Chairperson Martha Martin called the hybrid meeting to order at 3:00 pm.

Fire District Business

1. Chief Hartin went over the changes he made to the strategic plan. Discussion ensued.
2. Chief Hartin handed out a key message hand out for the lid lift message. He went through each one. Discussion ensued.
3. Chief Hartin showed a short demonstration on what the blue card training looks like on the iPad.

Public Input

No comments.

Adjournment

Meeting adjourned at 16:19.

Martha Martin, Chairperson

Michael Taggart, Vice Chair

Sherry Petty, Commissioner

Steve Hofmaster, Commissioner

Joshua Seeds, Commissioner

Attest

Debbie Macias, District Secretary
Ed Hartin, Chief (Alternate)

CHECK REGISTER

East County Fire & Rescue

Time: 08:48:59 Date: 12/14/2023

12/01/2023 To: 12/31/2023

Page: 1

Trans	Date	Type	Acct #	Chk #	Claimant	Amount	Memo
1292	12/07/2023	Claims	6291	14930	BLOOMQUIST SEPTIC INSPECTIONS	150.00	Invoice # 21498 - ST 91 Annual Inspection of septic system for Clark County Environmental Health Dept. Report sent to Clark County.
					001 - 522 50 40 000 - Bldg Repair & Maint	150.00	Annual Inspection of septic system for Clark County Environmental Health Dept. Station 91. Report sent to Clark County.
1293	12/07/2023	Claims	6291	14931	GENERAL FIRE APPARATUS, INC	1,935.27	Invoice # 17590 - Trident auto air primer 12v DC auto, 3/4" NPT for Apparatus 1014.; Invoice # 17574 - HME Windshield wiper arm, Qty (2). For Apparatus 1014.
					001 - 522 60 48 014 - E94 (1014)	1,453.25	Trident auto air primer 12v DC auto, 3/4" NPT for Apparatus 1014.
					001 - 522 60 48 014 - E94 (1014)	482.02	HME Windshield wiper arm, Qty (2). For Apparatus 1014.
1294	12/07/2023	Claims	6291	14932	HI-WAY FUEL	299.05	Account # 710 - November Fuel Charge
					001 - 522 20 36 000 - Diesel / Gas	299.05	November Fuel Charge
1295	12/07/2023	Claims	6291	14933	KONICA MINOLTA BUSINESS SOLUTIONS USA IN	30.48	Invoice # 290630725 - Copier maintenance at station 91.
					001 - 522 10 40 002 - Copier Mtce	30.48	Copier maintenance at station 91.
1296	12/07/2023	Claims	6291	14934	LES SCHWAB	1,477.19	Invoice # 71400584266 - Replace tires that have exceeded their acceptable lifespan per NFPA1911. Qty. (2) steer tires for Apparatus 914.
					001 - 522 60 48 914 - T94 (914)	1,477.19	Replace tires that have exceeded their acceptable lifespan per NFPA1911. Qty. (2) steer tires for Apparatus 914.
1297	12/07/2023	Claims	6291	14935	LIZ LOOMIS PUBLIC AFFAIRS	3,000.00	Invoice # EC-1223 - Support of official client business. Key messages for lid lift 2024.
					001 - 522 10 44 000 - Professional Services	3,000.00	Support of official client business. Key messages for lid lift 2024.
1298	12/07/2023	Claims	6291	14936	LN CURTIS & SONS	464.27	Invoice # INV765764 - App 1020 and 1014.(1) BIV valve rebuild kit. (1) Jumbo BIV valve rebuild kit. (20) plugs (1) Retaining strip tool. Tools to repair OOS intake valves. Tools to maintain valves
					001 - 522 60 48 014 - E94 (1014)	232.14	App 1014 (1) BIV valve rebuild kit. (10) plugs (1) Retaining strip tool. Tools to repair OOS intake valves. Tools to maintain valves
					001 - 522 60 48 020 - E91 (1020)	232.13	App 1020 (1) Jumbo BIV valve rebuild kit. (10) plugs (1) Retaining strip tool. Tools to repair OOS intake valves. Tools to maintain valves
1299	12/07/2023	Claims	6291	14937	LUTZ HARDWARE	135.33	Account # 1095 - November Statement.
					001 - 522 20 32 001 - Other Operating Supplies	22.75	Inv# A1220983 Gloves for fall hiring physical test.
					001 - 522 50 40 000 - Bldg Repair & Maint	9.75	Inv# A1223287 Sealant for well head at station 94.

CHECK REGISTER

East County Fire & Rescue

Time: 08:48:59 Date: 12/14/2023

12/01/2023 To: 12/31/2023

Page: 2

Trans	Date	Type	Acct #	Chk #	Claimant	Amount	Memo
			001 - 522 50 40 000		Bldg Repair & Maint	26.88	Inv# A1224134 Items to have on hand for repairs around all stations. 8oz 3 in 1 household oil, WD40, lock lubricant
			001 - 522 50 40 000		Bldg Repair & Maint	4.46	Inv# A1225742 100pk 3/4" cinch clamps and 100pk 1/2" cinch clamps for bldg maint at station 91.
			001 - 522 60 48 000		Vehicle Repair & Maint	71.49	Inv# A1224135 6" diagonal cut pliers 2qty, 100pc blk cable tie, tarp strap 6qty. Chain accessories for all apparatus and stations.
1300	12/07/2023	Claims	6291	14938	PACIFIC TRUCK & TRAILER SERVICE, INC	1,442.46	Invoice # 2023-35105 - Apparatus # 916 - Repair vacuum leaks at right side pump intake. Adjusted air cylinder on tank to pump valve. Replaced info IV panel on pump panel. Repaired engine coolant leak.
			001 - 522 60 48 916		E95 (916)	1,442.46	Apparatus # 916 - Repair vacuum leaks at right side pump intake. Adjusted air cylinder on tank to pump valve. Replaced info IV panel on pump panel. Repaired engine coolant leak.
1301	12/07/2023	Claims	6291	14939	PALADIN BACKGROUND SCREENING	205.00	Invoice # 5462 - Nationwide criminal background check on 3 new hires and 1 volunteer.
			001 - 522 10 44 000		Professional Services	51.00	Nationwide criminal background check. Volunteer (Pasquariello)
			001 - 522 10 44 000		Professional Services	51.00	Nationwide criminal background check. Part-time Firefighter (Manley)
			001 - 522 10 44 000		Professional Services	51.00	Nationwide criminal background check. Full-time firefighter (Lockwood)
			001 - 522 10 44 000		Professional Services	52.00	Nationwide criminal background check. Full-time firefighter (Miller)
1302	12/07/2023	Claims	6291	14940	SNURE LAW OFFICE, PSC	220.00	Invoice 11.10.2023 November services. Review of and revise Lacamas Park ILA, email Chief.
			001 - 522 10 42 000		Legal Services	220.00	Review of and revise Lacamas Park ILA, email Chief.
1303	12/07/2023	Claims	6291	14941	U.S. BANK (One Card)	7,237.00	Account ending in 3017 - November statement.
			001 - 522 10 30 000		Office Supplies	28.64	Amazon - White out and 1099 forms.
			001 - 522 10 30 002		UPS/Federal Express	21.07	UPS Store - - Ship air sample to Lawrence Factor.
			001 - 522 10 31 000		Furniture/Appliances	3,115.63	Zipchair - Replace (3qty) aging and damaged recliners in day room. Station 91.
			001 - 522 10 33 000		Computer/Software/Supplies	36.10	MX Guardian - Monthly fee for spam filter.
			001 - 522 10 33 000		Computer/Software/Supplies	17.24	Zoom - Video Streaming Service for Board Meetings.
			001 - 522 10 33 000		Computer/Software/Supplies	137.92	Amazon - iPad stands for blue card training. (8qty).
			001 - 522 10 34 000		Incentives And Awards	535.00	GSJS- Custom coin for member recognition (50qty).
			001 - 522 10 44 000		Professional Services	140.22	Pacific NW Pest Control - Pest control service at station 93.
			001 - 522 20 25 001		FF Uniforms	14.54	Amazon - Workout sweats 1 pr. (Dobbins)
			001 - 522 20 32 001		Other Operating Supplies	91.14	Amazon - Key storage box. Station 91.

CHECK REGISTER

East County Fire & Rescue

Time: 08:48:59 Date: 12/14/2023

12/01/2023 To: 12/31/2023

Page: 3

Trans	Date	Type	Acct #	Chk #	Claimant	Amount	Memo
			001 - 522 20 41 002		Verizon MDC Cards	160.04	Verizon - MDC
			001 - 522 20 41 003		Cell Phones E91 & E94	83.94	Verizon - Cell phones for E91 and E94.
			001 - 522 45 42 000		Lodging	-102.38	Hotels.com - Refund for hotel stay for training. (Sorensen)
			001 - 522 50 42 091		Comcast Tel/Internet (St 91)	447.71	Comcast - Telephone/Internet service at station 91. Service period 10/19/2023-11/18/2023.
			001 - 522 50 42 093		Comcast Tel/Internet (St 93)	320.13	Comcast - Telephone/Internet service at station 93. Service period 11/10/2023-12/09/2023.
			001 - 522 50 42 094		Comcast Tel/Internet (St 94)	445.24	Comcast - Telephone/Internet service at station 94. Service period 11/14/2023-12/13/2023.
			001 - 522 50 43 092		Electrical & Heating (St 92)	33.39	Clark Public Utilities- Electric service at station 92. Service period 9/22/2023-10/20/2023.
			001 - 522 50 43 093		Electrical & Htg (St 93)	428.04	Clark Public Utilites - Electric service at station 93. Service period 10/06/2023-11/07/2023.
			001 - 522 50 43 094		Electric & Heating (St 94)	92.76	Clark Public Utilities - Electric service at station 94. Service period 10/06/2023-11/07/2023.
			001 - 522 50 44 091		Garbage (St 91)	156.34	Waste Management - Trash service at station 91. Service period 10/1/2023-10/31/2023.
			001 - 522 50 44 093		Garbage (St 93)	136.76	Waste Management - Trash service at station 93. Temp pickup for October.
			001 - 522 50 44 094		Garbage (St 94)	69.00	Waste Management - Trash service at station 94. Service period 10/01/2023-10/31/2023.
			001 - 522 50 45 091		Gas (St 91)	456.29	NW Natural - Gas service at station 91. Service period 10/13/2023-11/14/2023.
			001 - 522 60 48 021		S91 (1021)	93.06	Image 360 - Replace damaged placard 3qty (1020)
			001 - 522 60 48 022		S94 (1022)	93.06	Image 360 - Replace damaged placard 3qty (1022)
			001 - 522 60 48 914		T94 (914)	93.06	Image 360 - Replace damaged placard 3 qty (914)
			001 - 522 60 48 919		T91 (919)	93.06	Image 360 - Replace damaged placard 3qty (919)
1304	12/07/2023	Claims	6291	14942	UNITED FIRE, HEALTH & SAFETY	2,318.03	Invoice # 00157980 - Annual Fire Extinguisher Inspection/Maintenance. All fire extinguishers at all stations were done at station 91.; Invoice # 00158551 - Annual Fire Alarm Testing at Station 93.
			001 - 522 50 40 000		Bldg Repair & Maint	485.12	Annual Fire Alarm Testing at Station 93.
			001 - 522 60 40 000		Fire Extinguisher Maint	1,832.91	Annual Fire Extinguisher Inspection/Maintenance. All fire extinguishers at all stations were done at station 91.
1305	12/07/2023	Claims	6291	14943	WEX BANK	1,386.91	Invoice # 93724563 - November Fuel Charge
			001 - 522 20 36 000		Diesel / Gas	1,386.91	November Fuel Charge
1306	12/07/2023	Payroll	6291	14944	NC DEPARTMENT OF REVENUE	181.93	Pay Cycle(s) 12/10/2023 To 12/10/2023 - Debbie S. Macias Garnishment

CHECK REGISTER

East County Fire & Rescue

Time: 08:49:45 Date: 12/14/2023

12/01/2023 To: 12/31/2023

Page: 1

Trans	Date	Type	Acct #	Chk #	Claimant	Amount	Memo
1262	12/10/2023	Payroll	6291	EFT		1,275.34	
1263	12/10/2023	Payroll	6291	EFT		2,372.40	
1264	12/10/2023	Payroll	6291	EFT		3,532.07	
1265	12/10/2023	Payroll	6291	EFT		2,294.12	
1266	12/10/2023	Payroll	6291	EFT		2,150.78	
1267	12/10/2023	Payroll	6291	EFT		2,942.91	
1268	12/10/2023	Payroll	6291	EFT		1,062.15	
1269	12/10/2023	Payroll	6291	EFT		233.45	
1270	12/10/2023	Payroll	6291	EFT		1,941.63	
1271	12/10/2023	Payroll	6291	EFT		1,054.55	
1272	12/10/2023	Payroll	6291	EFT		1,191.75	
1273	12/10/2023	Payroll	6291	EFT		116.72	
1274	12/10/2023	Payroll	6291	EFT		2,215.18	
1275	12/10/2023	Payroll	6291	EFT		116.72	
1276	12/10/2023	Payroll	6291	EFT		3,292.54	
1277	12/10/2023	Payroll	6291	EFT		116.72	
1278	12/10/2023	Payroll	6291	EFT		3,886.12	
1279	12/10/2023	Payroll	6291	EFT		116.72	
1280	12/10/2023	Payroll	6291	EFT		6,306.49	
1281	12/10/2023	Payroll	6291	EFT	IAFF2444	807.60	Pay Cycle(s) 12/10/2023 To 12/10/2023 - IAFF Dues
1282	12/10/2023	Payroll	6291	EFT	DEPT OF RETIREMENT SYSTEMS	6,920.44	Pay Cycle(s) 12/10/2023 To 12/10/2023 - LEOFF2
1283	12/10/2023	Payroll	6291	EFT	DEPT OF RETIREMENT SYSTEMS	719.81	Pay Cycle(s) 12/10/2023 To 12/10/2023 - PERS2
1284	12/10/2023	Payroll	6291	EFT	DEPT OF RETIREMENT SYSTEMS	376.37	Pay Cycle(s) 12/10/2023 To 12/10/2023 - PERS3
1285	12/10/2023	Payroll	6291	EFT	DEPT OF RETIREMENT SYSTEMS	3,004.80	Pay Cycle(s) 12/10/2023 To 12/10/2023 - DComp
1286	12/10/2023	Payroll	6291	EFT	DEPT OF RETIREMENT SYSTEMS	3,490.43	Pay Cycle(s) 12/10/2023 To 12/10/2023 - DComp Match
1287	12/10/2023	Payroll	6291	EFT	IRS	7,296.53	941 Deposit for Pay Cycle(s) 12/10/2023 - 12/10/2023
1288	12/10/2023	Payroll	6291	EFT	OR Department of Revenue	358.00	Pay Cycle(s) for OR Tax: 12/10/2023 - 12/10/2023
1289	12/10/2023	Payroll	6291	EFT	WASHINGTON STATE SUPPORT REGISTRY	700.00	Pay Cycle(s) 12/10/2023 To 12/10/2023 - WA Child Support

001 General Fund
007 Grants Management Fund

59,705.05
187.29

59,892.34 Payroll: 59,892.34

2023 BUDGET POSITION

East County Fire & Rescue

Time: 16:06:00 Date: 12/13/2023

Page: 1

001 General Fund Months: 01 To: 11

	Amt Budgeted	Revenues	Remaining	
--	--------------	----------	-----------	--

308 Beginning Balances

308 91 00 001 Beginning Balance (Unreserved)	2,053,597.21	2,053,597.21	0.00	0.0%
308 Beginning Balances	2,053,597.21	2,053,597.21	0.00	0.0%

310 Taxes

311 10 00 000 Leasehold Excise Tax	5,000.00	11,316.18	(6,316.18)	0.0%
311 10 00 001 Property Tax Collected	2,970,623.00	2,905,490.50	65,132.50	2.2%
311 10 00 002 Property Tax - Delinquent	10,000.00	0.00	10,000.00	100.0%
311 10 00 003 Admin Refund (CC Treasurer)	150.00	4,594.13	(4,444.13)	0.0%
311 10 00 004 Timber Excise Tax	1,500.00	17,601.98	(16,101.98)	0.0%
310 Taxes	2,987,273.00	2,939,002.79	48,270.21	1.6%

330 Intergovernmental Revenues

332 15 60 000 Steigerwald Wildlife Reserve	500.00	582.88	(82.88)	0.0%
334 04 90 000 EMS Participation Grant	1,125.00	554.00	571.00	50.8%
330 Intergovernmental Revenues	1,625.00	1,136.88	488.12	30.0%

340 Charges For Services

342 21 00 001 Wildland Firefighting-Personnel	5,000.00	31,965.01	(26,965.01)	0.0%
342 21 00 002 Wildland Firefighting-Equipment	5,000.00	4,213.00	787.00	15.7%
342 21 00 003 Ntnl Motocross Standby	2,100.00	2,173.69	(73.69)	0.0%
342 21 00 004 State School Fee	930.00	0.00	930.00	100.0%
340 Charges For Services	13,030.00	38,351.70	(25,321.70)	0.0%

360 Misc Revenue

361 10 00 000 Investment Interest (General Fund)	12,000.00	52,082.60	(40,082.60)	0.0%
362 00 00 000 DNR Timber Rents	0.00	0.00	0.00	100.0%
362 00 00 001 Station Use Fee	80.00	80.00	0.00	0.0%
367 00 00 000 Contributions & Donations	150.00	2,760.00	(2,610.00)	0.0%
369 10 00 000 Sale of Junk & Salvage	0.00	24,450.00	(24,450.00)	0.0%
369 91 00 000 Prior Year Refunds/Other Misc	50.00	323.00	(273.00)	0.0%
369 91 00 001 Other Misc. Revenue	50.00	47.35	2.65	5.3%
369 91 00 002 BVFF Refund for Vol Phys Exam	100.00	0.00	100.00	100.0%
369 91 00 003 P Card Rebate	200.00	1,656.33	(1,456.33)	0.0%
360 Misc Revenue	12,630.00	81,399.28	(68,769.28)	0.0%

390 Other Revenues

395 10 00 000 DNR Timber Sales	3,000.00	21,324.66	(18,324.66)	0.0%
390 Other Revenues	3,000.00	21,324.66	(18,324.66)	0.0%

397 Interfund Transfers

397 00 00 002 Transfer In- Equipment Reserve	50,000.00	50,000.00	0.00	0.0%
397 00 00 003 Transfer In-Apparatus Fund	325,000.00	325,000.00	0.00	0.0%

2023 BUDGET POSITION

East County Fire & Rescue

Time: 16:06:00 Date: 12/13/2023

Page: 2

001 General Fund Months: 01 To: 11

Revenues	Amt Budgeted	Revenues	Remaining	
397 Interfund Transfers				
397 00 00 004 Transfer In - Leave Accrual	4,486.36	4,486.36	0.00	0.0%
397 00 00 005 Transfer In- Plans Copier Reserve	0.00	2,231.61	(2,231.61)	0.0%
397 Interfund Transfers	379,486.36	381,717.97	(2,231.61)	0.0%
Fund Revenues:	5,450,641.57	5,516,530.49	(65,888.92)	0.0%
Expenditures	Amt Budgeted	Expenditures	Remaining	
597 Interfund Transfers				
597 22 50 000 Transfer Out To Grant Management Fund	12,111.29	0.00	12,111.29	100.0%
597 Interfund Transfers	12,111.29	0.00	12,111.29	100.0%
999 Ending Balance				
508 91 00 001 Ending Balance General Fund - Unreserved	0.00	0.00	0.00	100.0%
999 Ending Balance	0.00	0.00	0.00	100.0%

100 Administration

110 Commissioners				
522 10 11 001 Commissioner Wages	35,200.00	32,128.00	3,072.00	8.7%
522 10 21 001 Commissioner Payroll Benefits	2,693.00	2,457.82	235.18	8.7%
522 10 48 001 Commissioner Mileage	700.00	275.10	424.90	60.7%
522 10 48 002 Commissioner Meals	820.00	31.13	788.87	96.2%
522 10 48 003 Commissioner Lodging	2,550.00	601.23	1,948.77	76.4%
522 10 48 004 Commissioner Dues/Memberships	2,625.00	2,519.00	106.00	4.0%
522 10 48 005 Commissioner Tuition	3,460.00	842.50	2,617.50	75.7%
110 Commissioners	48,048.00	38,854.78	9,193.22	19.1%
210 Wages & Benefits				
522 10 10 001 Admin Wages	242,114.00	217,213.43	24,900.57	10.3%
522 10 14 001 Admin Overtime	2,000.00	1,773.11	226.89	11.3%
522 10 19 001 Admin Deferred Comp	14,875.00	12,982.94	1,892.06	12.7%
522 10 20 001 Admin Unemployment/Medicare	6,828.00	3,889.48	2,938.52	43.0%
522 10 22 001 Admin Medical Insurance	64,146.00	42,965.11	21,180.89	33.0%
522 10 25 001 Admin Uniforms	2,400.00	831.10	1,568.90	65.4%
522 10 26 001 Admin Disability	3,150.00	2,896.00	254.00	8.1%
522 10 26 002 Admin Retirement PERS	11,092.00	9,980.06	1,111.94	10.0%
522 10 27 001 Admin VEBA	4,000.00	4,000.00	0.00	0.0%
522 10 28 001 Admin Retirement LEOFF	7,814.00	7,011.22	802.78	10.3%
522 10 29 001 Admin L&I	1,010.00	1,156.98	(146.98)	0.0%
210 Wages & Benefits	359,429.00	304,699.43	54,729.57	15.2%

220 Supplies & Services

2023 BUDGET POSITION

East County Fire & Rescue

Time: 16:06:00 Date: 12/13/2023

Page: 3

001 General Fund

Months: 01 To: 11

Expenditures	Amt Budgeted	Expenditures	Remaining	
220 Supplies & Services				
522 10 24 001 Magellan - EAP	2,380.00	2,380.16	(0.16)	0.0%
522 10 30 000 Office Supplies	1,800.00	2,006.26	(206.26)	0.0%
522 10 30 001 Postage	450.00	329.88	120.12	26.7%
522 10 30 002 UPS/Federal Express	200.00	60.82	139.18	69.6%
522 10 31 000 Furniture/Appliances	5,000.00	1,225.37	3,774.63	75.5%
522 10 32 000 Cleaning and Sanitation	2,900.00	2,879.91	20.09	0.7%
522 10 33 000 Computer/Software/Supplies	4,000.00	2,236.04	1,763.96	44.1%
522 10 34 000 Incentives And Awards	3,750.00	1,298.30	2,451.70	65.4%
522 10 40 000 BIAS Financial Software	8,012.00	8,009.12	2.88	0.0%
522 10 40 001 Computer/Website Mtce & Repair	8,500.00	2,990.98	5,509.02	64.8%
522 10 40 002 Copier Mtce	300.00	436.94	(136.94)	0.0%
522 10 41 000 State Audit Costs	6,000.00	6,143.25	(143.25)	0.0%
522 10 42 000 Legal Services	4,000.00	1,210.00	2,790.00	69.8%
522 10 43 000 Medical/Drug Screen/Vaccinations	9,000.00	7,789.00	1,211.00	13.5%
522 10 44 000 Professional Services	15,000.00	5,097.45	9,902.55	66.0%
522 10 46 000 Taxes and Assessments	1,275.00	1,218.97	56.03	4.4%
522 10 49 000 Admin Tuition/Registration	2,000.00	1,322.50	677.50	33.9%
522 10 49 001 Admin Training Travel	800.00	416.58	383.42	47.9%
522 10 49 002 Admin Training Meals	400.00	372.27	27.73	6.9%
522 10 49 003 Admin Training Lodging	1,270.00	1,338.27	(68.27)	0.0%
522 20 42 000 Advertising	1,000.00	897.99	102.01	10.2%
522 20 42 001 Legal Notices	100.00	79.86	20.14	20.1%
522 20 45 001 Election Fees	6,000.00	0.00	6,000.00	100.0%
522 20 46 000 Bldgs/Liability/Equip Insuranc	58,815.00	61,867.84	(3,052.84)	0.0%
522 20 49 000 NFIRS/Fire Manager/Target Solutions	17,101.00	17,006.02	94.98	0.6%
220 Supplies & Services	160,053.00	128,613.78	31,439.22	19.6%
100 Administration	567,530.00	472,167.99	95,362.01	16.8%
200 Operations				
210 Wages & Benefits				
522 20 10 001 Firefighter Wages	1,001,775.00	860,950.42	140,824.58	14.1%
522 20 14 001 FF Overtime	305,000.00	278,337.03	26,662.97	8.7%
522 20 19 001 Capt/FF Deferred Comp	42,115.00	36,668.19	5,446.81	12.9%
522 20 20 001 FF Unemployment/Medicare	25,844.00	24,185.78	1,658.22	6.4%
522 20 22 001 FF Medical Insurance	186,363.00	156,573.95	29,789.05	16.0%
522 20 25 001 FF Uniforms	6,500.00	4,337.13	2,162.87	33.3%
522 20 26 001 FF Disability	13,142.00	9,801.66	3,340.34	25.4%
522 20 26 002 FF Retirement PERS	12,675.00	7,847.85	4,827.15	38.1%
522 20 27 001 FF VEBA	10,000.00	10,000.00	0.00	0.0%
522 20 28 001 FF Retirement LEOFF	62,420.00	59,153.78	3,266.22	5.2%
522 20 29 001 FF L&I	92,993.00	75,805.99	17,187.01	18.5%
589 99 99 000 Payroll Clearing	0.00	(226.27)	226.27	100.0%
210 Wages & Benefits	1,758,827.00	1,523,435.51	235,391.49	13.4%
215 Volunteer Benefits				

2023 BUDGET POSITION

East County Fire & Rescue

Time: 16:06:00 Date: 12/13/2023

Page: 4

001 General Fund Months: 01 To: 11

Expenditures	Amt Budgeted	Expenditures	Remaining	
--------------	--------------	--------------	-----------	--

215 Volunteer Benefits

522 20 11 001	Volunteer Stipends	19,770.00	5,283.75	14,486.25	73.3%
522 20 21 001	Medicare/SS Vol	1,515.00	455.50	1,059.50	69.9%
522 20 23 001	Intern Tuition Assistance	3,000.00	0.00	3,000.00	100.0%
215 Volunteer Benefits		24,285.00	5,739.25	18,545.75	76.4%

220 Supplies & Services

522 20 30 000	Maps/Books/ Periodicals	550.00	135.00	415.00	75.5%
522 20 31 000	Food and Water	1,500.00	455.30	1,044.70	69.6%
522 20 32 000	Expendable Equipment	1,000.00	4,776.56	(3,776.56)	0.0%
522 20 32 001	Other Operating Supplies	3,000.00	2,341.21	658.79	22.0%
522 20 32 002	Equipment	25,000.00	18,913.07	6,086.93	24.3%
522 20 32 003	Tech Rescue Equipment	3,000.00	3,588.60	(588.60)	0.0%
522 20 32 004	Hose & Nozzles	2,000.00	104.97	1,895.03	94.8%
522 20 33 000	Volunteer Uniforms	750.00	264.09	485.91	64.8%
522 20 33 001	T-Shirts/Sweatshirts	1,500.00	4,568.99	(3,068.99)	0.0%
522 20 34 000	Bldg Supplies/Facility Misc	1,500.00	1,126.23	373.77	24.9%
522 20 35 000	Address Signs	500.00	0.00	500.00	100.0%
522 20 36 000	Diesel / Gas	21,500.00	21,195.25	304.75	1.4%
522 20 38 000	Turn-Outs	65,000.00	13,098.33	51,901.67	79.8%
522 20 38 001	PPE Accessories	4,000.00	3,721.74	278.26	7.0%
522 20 40 000	Radio Dispatch	37,647.00	39,336.45	(1,689.45)	0.0%
522 20 41 001	Satellite Phone	375.00	235.18	139.82	37.3%
522 20 41 002	Verizon MDC Cards	2,040.00	1,760.44	279.56	13.7%
522 20 41 003	Cell Phones E91 & E94	1,224.00	920.60	303.40	24.8%
522 20 44 001	Dues/Memberships	4,000.00	3,856.60	143.40	3.6%
522 20 45 000	Volunteer Pensions	1,000.00	1,560.00	(560.00)	0.0%
220 Supplies & Services		177,086.00	121,958.61	55,127.39	31.1%

240 Wildland Wages & Benefits

522 20 11 002	Wildland Salary & Benefits	5,500.00	4,395.96	1,104.04	20.1%
522 20 14 002	Wildland Overtime	8,500.00	21,464.70	(12,964.70)	0.0%
240 Wildland Wages & Benefits		14,000.00	25,860.66	(11,860.66)	0.0%

200 Operations	1,974,198.00	1,676,994.03	297,203.97	15.1%
-----------------------	---------------------	---------------------	-------------------	--------------

300 Public Education

220 Supplies & Services

522 30 30 000	Educational Supplies	725.00	564.94	160.06	22.1%
522 30 40 000	Printing/Newsletter	4,000.00	2,189.76	1,810.24	45.3%
522 30 41 000	Postage for Newsletter	4,000.00	1,773.53	2,226.47	55.7%
522 30 42 000	Public Education Advertising	300.00	0.00	300.00	100.0%
220 Supplies & Services		9,025.00	4,528.23	4,496.77	49.8%

2023 BUDGET POSITION

East County Fire & Rescue

Time: 16:06:00 Date: 12/13/2023

Page: 5

001 General Fund Months: 01 To: 11

Expenditures	Amt Budgeted	Expenditures	Remaining	
--------------	--------------	--------------	-----------	--

300 Public Education	9,025.00	4,528.23	4,496.77	49.8%
-----------------------------	-----------------	-----------------	-----------------	--------------

400 Training

220 Supplies & Services

522 45 30 000	Books/Periodicals (Training)	4,000.00	3,147.76	852.24	21.3%
522 45 32 000	Food and Water (Training)	150.00	0.00	150.00	100.0%
522 45 33 000	Training Supplies	2,000.00	399.86	1,600.14	80.0%
522 45 40 000	Local/Long Distance Travel (Training)	500.00	808.45	(308.45)	0.0%
522 45 41 000	Meals (Training)	1,000.00	652.60	347.40	34.7%
522 45 42 000	Lodging	2,000.00	1,096.69	903.31	45.2%
522 45 43 000	Tuition	3,000.00	2,658.75	341.25	11.4%
522 45 43 001	Tuition Reimbursement-IAFF	10,000.00	0.00	10,000.00	100.0%

220 Supplies & Services	22,650.00	8,764.11	13,885.89	61.3%
-------------------------	-----------	----------	-----------	-------

522 Fire Control

522 45 31 000	Office Supplies (Training)	150.00	0.00	150.00	100.0%
---------------	----------------------------	--------	------	--------	--------

522 Fire Control	150.00	0.00	150.00	100.0%
------------------	--------	------	--------	--------

400 Training	22,800.00	8,764.11	14,035.89	61.6%
---------------------	------------------	-----------------	------------------	--------------

500 Equipment Repair & Maintenance

220 Supplies & Services

522 60 40 000	Fire Extinguisher Maint	1,800.00	0.00	1,800.00	100.0%
522 60 40 001	Exercise Equip Maint	2,500.00	0.00	2,500.00	100.0%
522 60 41 000	Pump/Hose & Nozzle Test/Mtce	10,500.00	9,693.04	806.96	7.7%
522 60 41 001	EMS Equipment Mtce	200.00	0.00	200.00	100.0%
522 60 41 002	Ladder Testing/Repair	1,000.00	677.50	322.50	32.3%
522 60 41 003	Hand Tool Maintenance	150.00	0.00	150.00	100.0%
522 60 41 004	SCBA Mtce	7,500.00	5,944.74	1,555.26	20.7%
522 60 42 000	Communication Equipment Repair/Mtce.	4,000.00	2,150.21	1,849.79	46.2%
522 60 43 000	Small Engine Repair	3,000.00	28.01	2,971.99	99.1%
522 60 47 001	Emergency Generators Repair/Mtce.	14,000.00	1,046.90	12,953.10	92.5%

220 Supplies & Services	44,650.00	19,540.40	25,109.60	56.2%
-------------------------	-----------	-----------	-----------	-------

500 Equipment Repair & Maintenance	44,650.00	19,540.40	25,109.60	56.2%
---	------------------	------------------	------------------	--------------

525 Disaster Services

525 Disaster Services

525 60 30 000	Disaster Preparedness	150.00	0.00	150.00	100.0%
---------------	-----------------------	--------	------	--------	--------

525 Disaster Services	150.00	0.00	150.00	100.0%
-----------------------	--------	------	--------	--------

2023 BUDGET POSITION

East County Fire & Rescue

Time: 16:06:00 Date: 12/13/2023

Page: 6

001 General Fund Months: 01 To: 11

Expenditures	Amt Budgeted	Expenditures	Remaining	
525 Disaster Services	150.00	0.00	150.00	100.0%

550 Apparatus Repair & Maintenance

220 Supplies & Services

522 60 48 000 Vehicle Repair & Maint	2,700.00	1,136.27	1,563.73	57.9%
522 60 48 001 T93 (1001)	2,250.00	1,720.13	529.87	23.5%
522 60 48 009 E93 (1009)	3,600.00	46.57	3,553.43	98.7%
522 60 48 010 T95 (1010)	2,250.00	0.00	2,250.00	100.0%
522 60 48 012 U93 (1012)	675.00	243.85	431.15	63.9%
522 60 48 013 S93 (1013)	3,600.00	2,852.22	747.78	20.8%
522 60 48 014 E94 (1014)	6,100.00	5,814.95	285.05	4.7%
522 60 48 018 C91 (1018) U92	4,665.00	4,065.38	599.62	12.9%
522 60 48 019 RH93 (1019)	675.00	713.38	(38.38)	0.0%
522 60 48 020 E91 (1020)	3,600.00	717.27	2,882.73	80.1%
522 60 48 021 S91 (1021)	2,250.00	2,657.99	(407.99)	0.0%
522 60 48 022 S94 (1022)	3,600.00	2,005.49	1,594.51	44.3%
522 60 48 909 E92 (909)	2,250.00	1,956.49	293.51	13.0%
522 60 48 914 T94 (914)	2,250.00	772.48	1,477.52	65.7%
522 60 48 915 U94 (915)	1,075.00	903.27	171.73	16.0%
522 60 48 916 E95 (916)	3,600.00	3,517.73	82.27	2.3%
522 60 48 919 T91 (919)	2,250.00	1,354.96	895.04	39.8%
220 Supplies & Services	47,390.00	30,478.43	16,911.57	35.7%
550 Apparatus Repair & Maintenance	47,390.00	30,478.43	16,911.57	35.7%

592 Debt Service

597 Interfund Transfers

597 22 00 001 Transfer Out- Debt Service Payment	199,300.00	199,300.00	0.00	0.0%
597 Interfund Transfers	199,300.00	199,300.00	0.00	0.0%
592 Debt Service	199,300.00	199,300.00	0.00	0.0%

594 Capital Expenditures

594 Capital Expenditures

594 22 60 000 Capital Purchases	18,500.00	16,490.60	2,009.40	10.9%
594 22 61 000 Computer Equip	16,000.00	12,802.32	3,197.68	20.0%
594 22 62 000 Offsets Over Est. Prop. Tax	0.00	0.00	0.00	100.0%
594 22 63 000 Offsets Est. Mob Equip. Rev	0.00	0.00	0.00	100.0%
594 22 64 000 New Apparatus	0.00	0.00	0.00	100.0%
594 Capital Expenditures	34,500.00	29,292.92	5,207.08	15.1%
594 Capital Expenditures	34,500.00	29,292.92	5,207.08	15.1%

2023 BUDGET POSITION

East County Fire & Rescue

Time: 16:06:00 Date: 12/13/2023

Page: 7

001 General Fund

Months: 01 To: 11

Expenditures	Amt Budgeted	Expenditures	Remaining	
--------------	--------------	--------------	-----------	--

600 Facilities

220 Supplies & Services

522 50 30 000	Grounds & Park	8,000.00	4,802.44	3,197.56	40.0%
522 50 40 000	Bldg Repair & Maint	107,647.00	74,988.90	32,658.10	30.3%
220 Supplies & Services		115,647.00	79,791.34	35,855.66	31.0%

691 Station 91

522 50 41 091	Monitoring (St 91)	549.00	463.16	85.84	15.6%
522 50 42 091	Comcast Tel/Internet (St 91)	4,426.00	3,898.60	527.40	11.9%
522 50 43 091	Electrical Service (St 91)	7,350.00	5,151.86	2,198.14	29.9%
522 50 44 091	Garbage (St 91)	1,912.00	1,701.96	210.04	11.0%
522 50 45 091	Gas (St 91)	10,918.00	7,612.54	3,305.46	30.3%
522 50 46 091	Water & Sewer (St 91)	893.00	796.47	96.53	10.8%
691 Station 91		26,048.00	19,624.59	6,423.41	24.7%

692 Station 92

522 50 43 092	Electrical & Heating (St 92)	1,243.00	884.78	358.22	28.8%
692 Station 92		1,243.00	884.78	358.22	28.8%

693 Station 93

522 50 41 093	Monitoring (St 93)	523.00	443.75	79.25	15.2%
522 50 42 093	Comcast Tel/Internet (St 93)	3,665.00	3,564.94	100.06	2.7%
522 50 43 093	Electrical & Htg (St 93)	5,810.00	4,644.70	1,165.30	20.1%
522 50 44 093	Garbage (St 93)	158.00	204.10	(46.10)	0.0%
693 Station 93		10,156.00	8,857.49	1,298.51	12.8%

694 Station 94

522 50 41 094	Monitoring (St 94)	810.00	681.24	128.76	15.9%
522 50 42 094	Comcast Tel/Internet (St 94)	4,298.00	3,977.80	320.20	7.4%
522 50 43 094	Electric & Heating (St 94)	8,930.00	5,996.85	2,933.15	32.8%
522 50 44 094	Garbage (St 94)	883.00	758.98	124.02	14.0%
694 Station 94		14,921.00	11,414.87	3,506.13	23.5%

600 Facilities

	168,015.00	120,573.07	47,441.93	28.2%
--	-------------------	-------------------	------------------	--------------

800 Fund Transfers

801 Transfer To Reserve Fund

597 22 49 000	Transfer Out To Capital Facility	0.00	0.00	0.00	100.0%
597 22 60 001	Transfer Out To Apparatus Reserve	0.00	21,150.00	(21,150.00)	0.0%
801 Transfer To Reserve Fund		0.00	21,150.00	(21,150.00)	0.0%

2023 BUDGET POSITION

East County Fire & Rescue

Time: 16:06:00 Date: 12/13/2023

Page: 8

Expenditures	Amt Budgeted	Expenditures	Remaining	
800 Fund Transfers	0.00	21,150.00	(21,150.00)	0.0%
Fund Expenditures:	3,079,669.29	2,582,789.18	496,880.11	16.1%
Fund Excess/(Deficit):	2,370,972.28	2,933,741.31		

2023 BUDGET POSITION TOTALS

East County Fire & Rescue

Months: 01 To: 11

Time: 16:06:00 Date: 12/13/2023

Page: 9

Fund	Revenue Budgeted	Received		Expense Budgeted	Spent	
001 General Fund	5,450,641.57	5,516,530.49	0.0%	3,079,669.29	2,582,789.18	16%
	5,450,641.57	5,516,530.49	0.0%	3,079,669.29	2,582,789.18	16.1%

2023 BUDGET POSITION

East County Fire & Rescue

Time: 16:06:24 Date: 12/13/2023

Page: 1

002 Apparatus Replacement Fund

Months: 01 To: 11

Revenues	Amt Budgeted	Revenues	Remaining		
308 Beginning Balances					
308 41 00 001 Beginning Balance Apparatus Replacement	691,355.43	691,355.43	0.00	0.0%	
308 Beginning Balances	691,355.43	691,355.43	0.00	0.0%	
360 Misc Revenue					
361 10 00 001 Investment Interest (Apparatus Reserve)	0.00	16,342.30	(16,342.30)	0.0%	
360 Misc Revenue	0.00	16,342.30	(16,342.30)	0.0%	
397 Interfund Transfers					
397 00 00 001 Transfer In-Apparatus Replacement	0.00	21,150.00	(21,150.00)	0.0%	
397 Interfund Transfers	0.00	21,150.00	(21,150.00)	0.0%	
Fund Revenues:	691,355.43	728,847.73	(37,492.30)	0.0%	
Expenditures	Amt Budgeted	Expenditures	Remaining		
597 Interfund Transfers					
597 22 60 003 Transfer From Apparatus Reserve To General Fund	325,000.00	325,000.00	0.00	0.0%	
597 Interfund Transfers	325,000.00	325,000.00	0.00	0.0%	
999 Ending Balance					
508 41 00 001 Ending Balance Apparatus Replacement	0.00	0.00	0.00	100.0%	
999 Ending Balance	0.00	0.00	0.00	100.0%	
Fund Expenditures:	325,000.00	325,000.00	0.00	0.0%	
Fund Excess/(Deficit):	366,355.43	403,847.73			

2023 BUDGET POSITION

East County Fire & Rescue

Time: 16:06:24 Date: 12/13/2023

Page: 2

003 Capital Facility Fund		Months: 01 To: 11			
Revenues	Amt Budgeted	Revenues	Remaining		
308 Beginning Balances					
308 41 00 002	Beginning Balance Capital Facility	268,686.03	268,686.03	0.00	0.0%
308 Beginning Balances		268,686.03	268,686.03	0.00	0.0%
360 Misc Revenue					
361 10 00 002	Investment Interest (Capital Facility)	0.00	6,306.82	(6,306.82)	0.0%
360 Misc Revenue		0.00	6,306.82	(6,306.82)	0.0%
397 Interfund Transfers					
397 00 00 000	Transfer In- Capital Facility	0.00	0.00	0.00	100.0%
397 Interfund Transfers		0.00	0.00	0.00	100.0%
Fund Revenues:		268,686.03	274,992.85	(6,306.82)	0.0%
Expenditures	Amt Budgeted	Expenditures	Remaining		
999 Ending Balance					
508 41 00 002	Ending Balance Capital Facility	0.00	0.00	0.00	100.0%
999 Ending Balance		0.00	0.00	0.00	100.0%
Fund Expenditures:		0.00	0.00	0.00	100.0%
Fund Excess/(Deficit):		268,686.03	274,992.85		

2023 BUDGET POSITION

East County Fire & Rescue

Time: 16:06:24 Date: 12/13/2023

Page: 3

004 Leave Accrual Fund		Months: 01 To: 11			
Revenues	Amt Budgeted	Revenues	Remaining		
308 Beginning Balances					
308 41 00 003	Beginning Balance Leave Accrual	46,325.50	46,325.50	0.00	0.0%
308 Beginning Balances		46,325.50	46,325.50	0.00	0.0%
360 Misc Revenue					
361 10 00 003	Investment Interest (Leave Accrual)	0.00	1,059.18	(1,059.18)	0.0%
360 Misc Revenue		0.00	1,059.18	(1,059.18)	0.0%
Fund Revenues:		46,325.50	47,384.68	(1,059.18)	0.0%
Expenditures	Amt Budgeted	Expenditures	Remaining		
999 Ending Balance					
508 41 00 003	Ending Balance Leave Accrual	0.00	0.00	0.00	100.0%
999 Ending Balance		0.00	0.00	0.00	100.0%
800 Fund Transfers					
801 Transfer To Reserve Fund					
597 22 64 004	Transfer Out To General Fund	4,486.36	4,486.36	0.00	0.0%
801 Transfer To Reserve Fund		4,486.36	4,486.36	0.00	0.0%
800 Fund Transfers		4,486.36	4,486.36	0.00	0.0%
Fund Expenditures:		4,486.36	4,486.36	0.00	0.0%
Fund Excess/(Deficit):		41,839.14	42,898.32		

2023 BUDGET POSITION

East County Fire & Rescue

Time: 16:06:24 Date: 12/13/2023

Page: 4

005 Plans Trailer Copier Months: 01 To: 11

	Amt Budgeted	Revenues	Remaining	
--	--------------	----------	-----------	--

308 Beginning Balances

308 41 00 004 Beginning Balance Plans Trailer Copier	2,209.89	2,209.89	0.00	0.0%
308 Beginning Balances	2,209.89	2,209.89	0.00	0.0%

360 Misc Revenue

361 10 00 005 Investment Interest (Copier Reserve)	0.00	21.72	(21.72)	0.0%
360 Misc Revenue	0.00	21.72	(21.72)	0.0%

Fund Revenues:	2,209.89	2,231.61	(21.72)	0.0%
-----------------------	-----------------	-----------------	----------------	-------------

	Amt Budgeted	Expenditures	Remaining	
--	--------------	--------------	-----------	--

597 Interfund Transfers

597 22 00 005 Transfer Out to General Fund	0.00	2,231.61	(2,231.61)	0.0%
597 Interfund Transfers	0.00	2,231.61	(2,231.61)	0.0%

999 Ending Balance

508 41 00 004 Ending Balance Copier	0.00	0.00	0.00	100.0%
999 Ending Balance	0.00	0.00	0.00	100.0%

Fund Expenditures:	0.00	2,231.61	(2,231.61)	0.0%
---------------------------	-------------	-----------------	-------------------	-------------

Fund Excess/(Deficit):	2,209.89	0.00		
-------------------------------	-----------------	-------------	--	--

2023 BUDGET POSITION

East County Fire & Rescue

Time: 16:06:24 Date: 12/13/2023

Page: 5

006 Equipment Reserve Fund		Months: 01 To: 11			
Revenues	Amt Budgeted	Revenues	Remaining		
308 Beginning Balances					
308 41 00 005	Beginning Balance Equipment Reserve	113,335.24	113,335.24	0.00	0.0%
308 Beginning Balances		113,335.24	113,335.24	0.00	0.0%
360 Misc Revenue					
361 10 00 004	Investment Interest (Equipment Reserve)	0.00	2,641.41	(2,641.41)	0.0%
360 Misc Revenue		0.00	2,641.41	(2,641.41)	0.0%
Fund Revenues:		113,335.24	115,976.65	(2,641.41)	0.0%
Expenditures	Amt Budgeted	Expenditures	Remaining		
597 Interfund Transfers					
597 22 61 002	Transfer Out To General Fund	50,000.00	50,000.00	0.00	0.0%
597 Interfund Transfers		50,000.00	50,000.00	0.00	0.0%
999 Ending Balance					
508 41 00 005	Ending Balance Equipment Resere	0.00	0.00	0.00	100.0%
999 Ending Balance		0.00	0.00	0.00	100.0%
Fund Expenditures:		50,000.00	50,000.00	0.00	0.0%
Fund Excess/(Deficit):		63,335.24	65,976.65		

2023 BUDGET POSITION

East County Fire & Rescue

Time: 16:06:24 Date: 12/13/2023

Page: 6

007 Grants Management Fund Months: 01 To: 11

Revenues	Amt Budgeted	Revenues	Remaining	
308 Beginning Balances				
308 31 00 050 EMW-22-FG-01031 Beginning Balance	0.00	0.00	0.00	100.0%
308 Beginning Balances	0.00	0.00	0.00	100.0%
330 Intergovernmental Revenues				
331 97 00 050 AFG Grant EMW-22-FG-01031	242,225.71	12,518.42	229,707.29	94.8%
330 Intergovernmental Revenues	242,225.71	12,518.42	229,707.29	94.8%
397 Interfund Transfers				
397 00 00 050 EMW-22-FG-01031 5% Match	12,111.29	0.00	12,111.29	100.0%
397 Interfund Transfers	12,111.29	0.00	12,111.29	100.0%
Fund Revenues:	254,337.00	12,518.42	241,818.58	95.1%
Expenditures	Amt Budgeted	Expenditures	Remaining	
522 Fire Control				
522 10 33 050 Computer Software (Other)	5,952.00	2,500.96	3,451.04	58.0%
522 45 14 050 Overtime-EMW-22-FG-01031(Personnel)	11,323.00	909.67	10,413.33	92.0%
522 45 41 050 Fire Training TLM (Travel)	1,790.00	1,380.95	409.05	22.9%
522 45 41 051 Fire Training Registration (Contractual)	7,272.00	7,272.00	0.00	0.0%
522 Fire Control	26,337.00	12,063.58	14,273.42	54.2%
594 Capital Expenditures				
594 22 63 050 Facilities (Equipment)	228,000.00	0.00	228,000.00	100.0%
594 Capital Expenditures	228,000.00	0.00	228,000.00	100.0%
Fund Expenditures:	254,337.00	12,063.58	242,273.42	95.3%
Fund Excess/(Deficit):	0.00	454.84		

2023 BUDGET POSITION TOTALS

East County Fire & Rescue

Months: 01 To: 11

Time: 16:06:24 Date: 12/13/2023

Page: 7

Fund	Revenue Budgeted	Received		Expense Budgeted	Spent	
002 Apparatus Replacement Fund	691,355.43	728,847.73	0.0%	325,000.00	325,000.00	0%
003 Capital Facility Fund	268,686.03	274,992.85	0.0%	0.00	0.00	100%
004 Leave Accrual Fund	46,325.50	47,384.68	0.0%	4,486.36	4,486.36	0%
005 Plans Trailer Copier	2,209.89	2,231.61	0.0%	0.00	2,231.61	0%
006 Equipment Reserve Fund	113,335.24	115,976.65	0.0%	50,000.00	50,000.00	0%
007 Grants Management Fund	254,337.00	12,518.42	95.1%	254,337.00	12,063.58	95%
	1,376,249.09	1,181,951.94	14.1%	633,823.36	393,781.55	37.9%



East County Fire and Rescue

600 NE 267th Avenue Camas, WA 98607

(360) 834-4908 (phone)

(360) 835-8920 (fax)

www.ecfr.us



To: Board of Fire Commissioners
From: Chief Ed Hartin
Date: December 19, 2023
Subject: Chief's Report

Response Activity

December 1st through December 17th the district responded to 28 calls for service. Table 1 outlines the distribution of incidents by incident type series.

Table 1. Response Activity

Incident Type Series	Number
1 - Fire	2
3 - Rescue & Emergency Medical Service Incident	12
4 - Hazardous Condition (No Fire)	3
5 - Service Call	3
6 - Good Intent Call	8
7 - False Alarm & False Call	0
Total Responses	28

Staffing and Deployment

On Thursday, September 14, 2023, Engine, Water Tender, and Squad 94 were relocated to Station 93 for the duration of mold remediation and restoration at Station 94. Response from Station 93 will result in longer response times to fire management zones 94 and 95 and potentially dispatch of Engine 43 on high acuity calls in these areas even if Station 93 is staffed.

During the month of December to date, the district projects a 90th percentile¹ shift staffing level of 2 personnel during the day (07:00-19:00) and 2 personnel at night (19:00-07:00). Station 93 will be unstaffed 25 times for a full shift (07:00-07:00) during the month to date and as such, its availability of response from this station was 19.35%. Daily shift staffing is illustrated in Figure 1.

Staffing during the month of December was impacted by the large number of vacancies and despite the mid-year budget amendment, limited funding in the overtime line as well as limited staff availability. Due to limited overtime funds, callback during the month of December was limited to maintaining a

¹ Calculation of the 90th percentile reflects the staffing that is available 90% of the time.

minimum of two person staffing at Station 91. As staffing is known for the remainder of the month, Figures 1 and 2 illustrated staffing and availability for the full month.

Figure 1. December Daily Shift Staffing

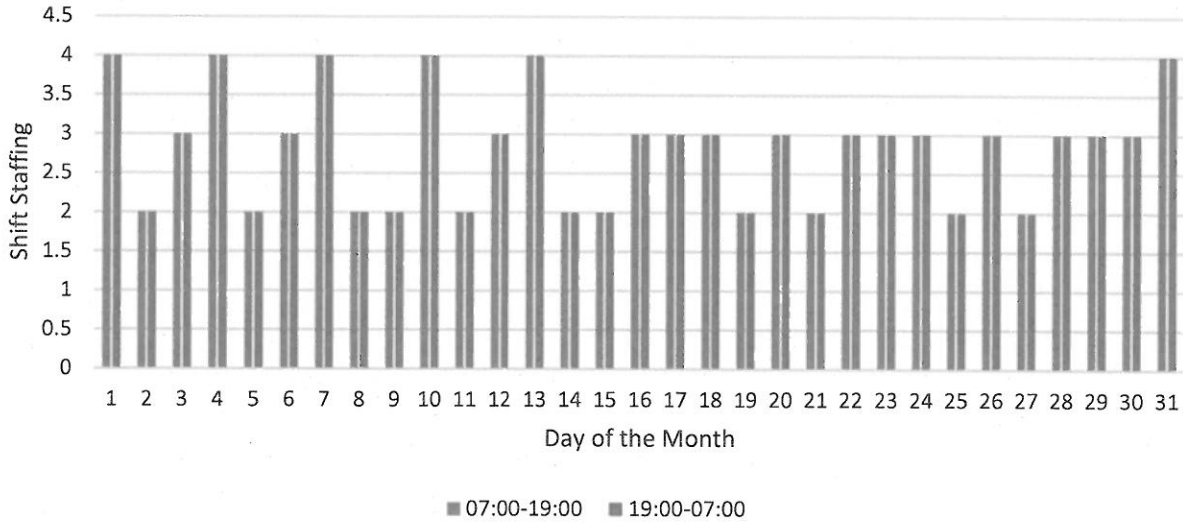
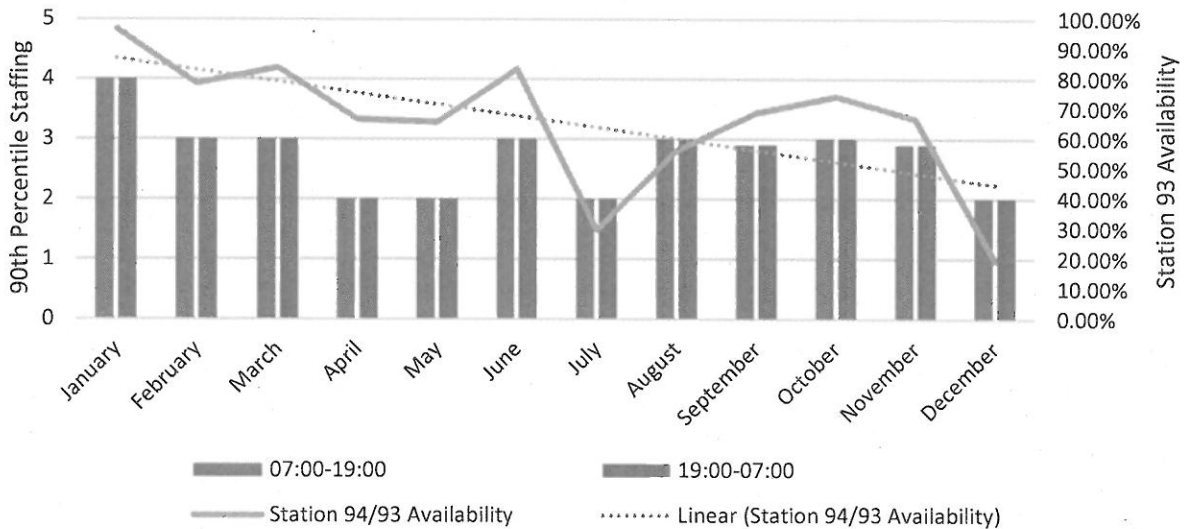

Figure 2. 90th Percentile Shift Staffing and Station 94/93 Availability for Response



From December 1st to the 17th, 8 incidents were impacted by lack of staffing at Station 94/93 as illustrated in Table 2. Four of these incidents were high-acuity, priority one and two responses (all of which were handled with an extended response time by Camas Washougal Fire Department Engine 43).

Table 2. Incidents Impacted by Unavailability for Response from Station 94/93

Date	Time	FMZ	Priority	Event Type	First Due
12/6/2023	7:21	95	3	FALLS	SQ91
12/8/2023	14:09	94	5	SICK PERSON	SQ91
12/9/2023	9:59	94	1	CHEST PAIN	E43
12/11/2023	7:42	94	3	TRAFFIC/TRANSPORTATION ACCIDENTS	E91
12/14/2023	21:18	95	1	CHEST PAIN	E43
12/15/2023	13:20	94	1	CHEST PAIN	E43
12/16/2023	2:42	94	2	BREATHING PROBLEMS	E43
12/17/2023	0:00	95	6	PUBLIC ASSIST/SERVICE CALL	M43

Shift Reports

A Shift/Training: Training this month has included emergency medical service ongoing training and evaluation on advanced airway management, Blue Card on-line training, fire ground hydraulics, and hazmat and incident management training on flammable gas incidents.

B Shift/Facilities and Community Risk Reduction: A major decluttering and clean-up project is underway at Station 94 and three of the day room chairs at Station 91 have been replaced.

C Shift/Apparatus and Equipment: Specifications have been completed for the new type one engine and all documentation is in place for procurement through a Sourcewell joint purchase contract with Rosenbauer America. A recommendation has been transmitted to the board for consideration at their regular meeting on December 19th.

Programs and Projects

Diesel Exhaust Extraction Systems: The bid was awarded based on the lowest acceptable bid and signed contracts returned to Plymovent. Station 93 will be used as the laydown area for equipment prior to installation at Stations 91, 94, and 93. Lead time for delivery is approximately 10 weeks, so we anticipate this project to commence in late February or early March.

Check It and Crew Sense: The district is on schedule to have both the Check It inventory and apparatus inspection system and Crew Sense scheduling system in place and on-line by January 1st.

ESO Records Management System: ESO is completing integration with the computer aided dispatch (CAD) system and end user training is scheduled for early January. As such the district will miss our target of implementation by January 1st, but should have the new records management system in place by the end of next month.

Firewise: Chief Hartin assisted the Autumn Hills Home Owners Association with completion of the wildland interface risk assessment for their renewal as a Firewise community. Autumn Hills is the only Firewise community in Clark County and has been a program participant since 2010. We will be working to expand the number of Firewise communities within East County Fire and Rescue's response area over the next several years.

Emergency Preparedness: Chief Hartin attended an emergency preparedness briefing held by the Church of Jesus Christ of Latter Day Saints at Washougal City Hall on December 11, 2023. City Councilor Suggs presented on how the church could assist local communities in the event of a disaster including providing shelter facilities and a wide range of volunteer support.



East County Fire and Rescue

600 NE 267th Avenue Camas, WA 98607

(360) 834-4908 (phone)

(360) 835-8920 (fax)

www.ecfr.us



To: Board of Fire Commissioners
From: Assistant Chief Robert Jacobs
Date: December 19, 2023
Subject: Assistant Chief's Report

Training

November DOC was 11.14.2023.

No DOC training in December.

January DOC training will be 01.09.2024 Sta. 91 7PM.

November EST/Training was 11.27.2023.

No EST training in December.

January EST/Tender training will be 01.22.2024 Sta. 91 7PM.

T94 annual and modifications are completed. Added pump test ports and generator fuel connections for station 94 generator.

Safety

Last safety committee meeting was 11.22.2023

Next safety committee meeting will be 01.25.2024 Sta. 91 7:30 PM.

No reported accidents/incidents since your last board meeting.



East County Fire and Rescue

600 NE 267th Avenue Camas, WA 98607

(360) 834-4908 (phone)

(360) 835-8920 (fax)

www.ecfr.us →



Safety Committee Meeting Minutes

November 22, 2023

There were no accident/incident report to review, thanks to all for working safely.

Reviewed station safety inspections, the mold removal and repairs at Sta. 94 have been completed, waiting for kitchen cabinets.

Request for bids to install exhaust extraction equipment at station 91, 93, and 94 in in process.

Winter will be here soon, be sure that all winter equipment is in place, remember, shoe chains when needed.

Before winter hits us, be sure to review the tire chain installation information, so that we avoid damage to tire chains on our apparatus.

Next safety committee meeting will be 01.25.2024 at Sta. 91 at 7:30 PM.



East County Fire and Rescue

600 NE 267th Avenue Camas, WA 98607

(360) 834-4908 (phone)

(360) 835-8920 (fax)

www.ecfr.us



Resolution 337-12192023

A resolution providing for disposal of equipment deemed to be surplus to the reasonably foreseeable needs of East County Fire and Rescue.

WHEREAS, the equipment shown in Attachment A, (Multiple Items) belonging to East County Fire & Rescue is, deemed obsolete and no longer needed by the district.

NOW, THEREFORE, BE IT RESOLVED by the Board of Commissioners of East County Fire & Rescue as follows:

1. Based upon the findings and recommendations of the Fire Chief, this equipment is surplus to the foreseeable needs of the district.
2. Disposal of this equipment will benefit the district.
3. The fire chief is authorized dispose of this equipment in a manner that will be to the best advantage of East County Fire and Rescue.

ADOPTED at a Regular Meeting of the Board of Commissioners for East County Fire and Rescue December 19, 2023, with the following Commissioners being present and voting:

Martha Martin, Chairperson

Michael Taggart, Vice Chair

Sherry Petty, Commissioner

Steve Hofmaster, Commissioner

Joshua Seeds, Commissioner

Attest

Debbie Macias, District Secretary



East County Fire and Rescue

600 NE 267th Avenue Camas, WA 98607

(360) 834-4908 (phone)

(360) 835-8920 (fax)

www.ecfr.us



Tag Number	Description of Asset	Serial Number	Status of Asset Choose One			Comments
			Lost	Stolen	Sell	
0180	Minitor					OBSOLETE
0185	Minitor				X	OBSOLETE
0186	Minitor				X	OBSOLETE
0187	Minitor				X	OBSOLETE
0188	Minitor				X	OBSOLETE
0422	Minitor				X	OBSOLETE
0441	Minitor				X	OBSOLETE
0442	Minitor				X	OBSOLETE
0472	Minitor				X	OBSOLETE
0475	Minitor				X	OBSOLETE
0655	Minitor				X	OBSOLETE
CCFD1-0180	Minitor				X	OBSOLETE
CCFD1-0181	Minitor				X	OBSOLETE
CCFD1-0183	Minitor				X	OBSOLETE
CCFD1-0184	Minitor				X	OBSOLETE
CCFD1-0185	Minitor				X	OBSOLETE
CCFD1-0187	Minitor				X	OBSOLETE
CCFD1-0188	Minitor				X	OBSOLETE
CCFD1-0189	Minitor				X	OBSOLETE
CCFD1-0190	Minitor				X	OBSOLETE
CCFD1-0191	Minitor				X	OBSOLETE
CCFD1-0197	Minitor				X	OBSOLETE
CCFD1-0198	Minitor				X	OBSOLETE
CCFD1-0199	Minitor				X	OBSOLETE
CCFD1-0200	Minitor				X	OBSOLETE
CCFD1-0207	Minitor				X	OBSOLETE
CCFD1-0209	Minitor				X	OBSOLETE
CCFD1-0210	Minitor				X	OBSOLETE
CCFD1-0211	Minitor				X	OBSOLETE
CCFD1-0218	Minitor				X	OBSOLETE
CCFD1-0219	Minitor				X	OBSOLETE
0292	Minitor				X	OBSOLETE

Attachment A

page 1

Property Salvage Report

Tag Number	Description of Asset	Serial Number	Status of Asset Choose One				Comments
			Lost	Broken	Sell	Recycle/Scrap	
0033	Minitor					X	OBSOLETE
0034	Minitor					X	OBSOLETE
0219	Minitor					X	OBSOLETE
0221	Minitor					X	OBSOLETE
0223	Minitor					X	OBSOLETE
0299	Minitor					X	OBSOLETE
0218	Minitor					X	OBSOLETE
0293	Minitor					X	OBSOLETE
0061	Thermal Imaging Camera					X	OBSOLETE
0496	Thermal Imaging Camera					X	OBSOLETE
CCFD1-0111	Thermal Imaging Camera					X	OBSOLETE
0592	TV/VCR Combo					X	OBSOLETE
CCFD1-0090	TV/VCR Combo					X	OBSOLETE

Attachment A

Page 2



East County Fire and Rescue

600 NE 267th Avenue Camas, WA 98607

(360) 834-4908 (phone)

(360) 835-8920 (fax)

www.ecfr.us



Property Salvage Report

Tag Number	Description of Asset	Serial Number	Status of Asset/Chose One				Comments
			Lost	Stolen	Sell	Recycle/Scrap	
0309	Braun tympanic Thermometer	11108964702	<input type="checkbox"/>	<input type="checkbox"/>	<input type="checkbox"/>	<input checked="" type="checkbox"/>	OOS
0652	Nonin pulse oximeter	124702903	<input type="checkbox"/>	<input type="checkbox"/>	<input type="checkbox"/>	<input checked="" type="checkbox"/>	OOS
0625	Nonin pulse oximeter	102839214	<input type="checkbox"/>	<input type="checkbox"/>	<input type="checkbox"/>	<input checked="" type="checkbox"/>	OOS
0115	Nonin pulse oximeter	124704815	<input type="checkbox"/>	<input type="checkbox"/>	<input type="checkbox"/>	<input checked="" type="checkbox"/>	OOS
0053	Nonin pulse oximeter	HH27701	<input type="checkbox"/>	<input type="checkbox"/>	<input type="checkbox"/>	<input checked="" type="checkbox"/>	OOS
0112	Laerdal suction unit	PL160126	<input type="checkbox"/>	<input type="checkbox"/>	<input type="checkbox"/>	<input checked="" type="checkbox"/>	OOS
0310	Nonin pulse oximeter	500266387	<input type="checkbox"/>	<input type="checkbox"/>	<input type="checkbox"/>	<input checked="" type="checkbox"/>	OOS
0046	Nonin pulse oximeter	102839070	<input type="checkbox"/>	<input type="checkbox"/>	<input type="checkbox"/>	<input checked="" type="checkbox"/>	OOS
0047	Laerdal suction unit	10033-E104	<input type="checkbox"/>	<input type="checkbox"/>	<input type="checkbox"/>	<input checked="" type="checkbox"/>	OOS
0477	Laerdal suction unit	L51002347	<input type="checkbox"/>	<input type="checkbox"/>	<input type="checkbox"/>	<input checked="" type="checkbox"/>	OOS
0112	Laerdal suction unit	5501-G230	<input type="checkbox"/>	<input type="checkbox"/>	<input type="checkbox"/>	<input checked="" type="checkbox"/>	OOS
0066	Laerdal suction unit	11110-C0G375	<input type="checkbox"/>	<input type="checkbox"/>	<input type="checkbox"/>	<input checked="" type="checkbox"/>	OOS
0023	Laerdal suction unit	16892	<input type="checkbox"/>	<input type="checkbox"/>	<input type="checkbox"/>	<input checked="" type="checkbox"/>	OOS
0197	Nonin pulse oximeter	500041074	<input type="checkbox"/>	<input type="checkbox"/>	<input type="checkbox"/>	<input checked="" type="checkbox"/>	OOS
0323	Braun Thermometer	n/a	<input type="checkbox"/>	<input type="checkbox"/>	<input type="checkbox"/>	<input checked="" type="checkbox"/>	OOS
0824	Braun Thermometer	11109069113	<input type="checkbox"/>	<input type="checkbox"/>	<input type="checkbox"/>	<input checked="" type="checkbox"/>	OOS
	1 3/4 50' section of hose	15-116	<input type="checkbox"/>	<input type="checkbox"/>	<input type="checkbox"/>	<input checked="" type="checkbox"/>	Damaged beyond repair
			<input type="checkbox"/>	<input type="checkbox"/>	<input type="checkbox"/>	<input type="checkbox"/>	

Attachment A Page 3



East County Fire and Rescue

600 NE 267th Avenue Camas, WA 98607

(360) 834-4908 (phone)

(360) 835-8920 (fax)

www.ecfr.us



Resolution #338-12192023

A resolution authorizing the purchase of a type one fire engine to replace Apparatus 1014, currently in-service as Engine 94.

WHEREAS, Apparatus 1014 has passed the recommended age for fire apparatus in front line service and is approaching its end of useful life; and

WHEREAS, the 5-year maintenance and repair expense for this apparatus is over 47% of the total expense for maintaining the district's fire engines; and

WHEREAS, the district's capital projects schedule and adopted 2024 comprehensive district budget have programmed replacement of this apparatus in 2024; and

WHEREAS, purchase of this apparatus using Sourcewell group purchase contract #113021-RSD saves the district 15% over the Rosenbauer's suggested retail price; and

WHEREAS, Rosenbauer will increase the price of fire engines 6% on January 1, 2024; and

WHEREAS, Rosenbauer is unable to provide a firm price based on the district's current type one engine specifications, and

WHEREAS, execution of a contract based on the as-built specifications for Apparatus 1020, currently in-service as Engine 91 and implementation of change orders within 60 days of the execution of this contract to ensure that the new type one engine meets the current needs of the district will save the district at least 6% of the total cost of this capital project.

NOW, THEREFORE, BE IT RESOLVED:

That the district will execute the attached contract for purchase of a type one fire engine with pricing based on Sourcewell Contract #113021-RSD and the as-built specifications for Apparatus 1020, currently in-service as Engine 91 and will make change orders within 60 days of the execution of this contract to ensure that the new type one engine meets the current needs of the district.

ADOPTED at a Regular Meeting of the Board of Commissioners for East County Fire and Rescue December 19, 2023, with the following Commissioners being present and voting:

Martha Martin, Chairperson

Michael Taggart, Vice Chair

Sherry Petty, Commissioner

Steve Hofmaster, Commissioner

Joshua Seeds, Commissioner

Attest

Debbie Macias, District Secretary
Ed Hartin, Chief (Alternate)

East County Fire & Rescue
600 NE 267th Avenue
Fire Station
Camas , Washington 98607



Date: December 6, 2023

One (1) Rosenbauer Pumper, complete with Rosenbauer Commander chassis per attached specifications.	\$823,127.00 each
Washington Sales Tax Applied At Final Invoice. Pricing Using Sourcewell Contract #113021-RSD, Is Valid until 12/30/2023 or Add 6% To The Contract Price Amount if not Signed & Returned by 12/30/2023	
Gross due upon completion and delivery total	TOTAL \$823,127.00
*Note: If chassis amount of \$394,483.00 is paid upon arrival at our plant in South Dakota, deduct \$15,144.00 each	

All of which are to be built in accordance with the specifications, clarifications and exceptions attached, and which are made a part of this agreement and contract.

DELIVERY:

The estimated delivery time for the completed apparatus, is to be made 545 days after receipt of and approval of this contract duly executed and approved production ready specifications are released, (chassis and (or) major components must arrive within 455 days or delivery may be extended), subject to all causes beyond the Company's control. The quoted delivery time is based upon our receipt of the specified materials required to produce the apparatus in a timely manner. "Delivery" means the date company is prepared to make physical possession of vehicle available to customer.

CONTRACT CHANGES:

After execution and acceptance of this Contract, the Buyer may request that the Company incorporate a change to the Products or the Specifications for the Products by delivering a Change Order to the Company; provided, however, that any such Change Order must be in writing and include a description of the proposed change sufficient to permit the Company to evaluate the feasibility of such Change Order. Within seven (7) working days of receipt of a Change Order, the Company will inform the Buyer in writing of the feasibility of the Change Order, the earliest possible implementation date for the Change Order, of any increase or decrease in the Purchase Price resulting from such Change Order, and of any effect on production scheduling or delivery resulting from such Change Order. The Company shall not be liable to the Buyer for any delay in performance or delivery arising from any such Change Order. Purchase Price may be modified only by mutual written agreement of the Parties because of changes to the Apparatus required or requested by the Buyer during the construction process pursuant to Appendix C, Change Order Policy. Any changes in the Purchase Price resulting from changes to the Apparatus required or requested by the Buyer during the construction process shall be stated in the Change Order signed by both parties. Additional Changes: If various state or federal regulatory agencies (e.g. NFPA, DOT, EPA) require changes to the specification and/or the product that result in a cost increase to comply therewith this cost will be added to the Purchase Price to be paid by the customer.

FORCE MAJEURE:

The Company shall not be responsible nor deemed to be in default on account of delays in performance due to causes which are beyond the Company's control which make the Company's performance impracticable, including but not limited to civil wars, insurrections, strikes, riots, fires, storms, floods, other acts of nature, explosions, earthquakes, accidents, any act of government, delays in transportation, inability to obtain necessary labor supplies or manufacturing facilities, allocation regulations or orders affecting materials, equipment, facilities or completed products, failure to obtain any required license or certificates, acts of God or the public enemy or terrorism, failure of transportation, epidemics, quarantine restrictions, failure of vendors (due to causes similar to those within the scope of this clause) to perform their contracts or labor troubles causing cessation, slowdown, or interruption of work.

www.rosenbaueramerica.com

info@rosenbaueramerica.com

ROSENBAUER SOUTH DAKOTA, LLC.
100 THIRD STREET
P.O. BOX 57
LYONS, SOUTH DAKOTA 57041
P: 605.543.5591

ROSENBAUER MINNESOTA, LLC.
5181 260TH STREET
P.O. BOX 549
WYOMING, MINNESOTA 55092
P: 651.462.1000

ROSENBAUER MOTORS, LLC.
5190 260TH STREET
P.O. BOX 549
WYOMING, MINNESOTA 55092
P: 651.462.1000

ROSENBAUER AERIALS, LLC.
870 SOUTH BROAD STREET
FREMONT, NEBRASKA 68025
P: 402.721.7822



PAYMENT TERMS:

Final payment for the apparatus shall be made at time of delivery or pick up of the completed vehicle. It is the responsibility of the Buyer to have full payment ready when the apparatus is complete and ready to deliver. If payment is delayed or delivery is delayed pending payment, a daily finance and storage fee may apply. Upon delivery of the apparatus or upon pickup of the apparatus by the Buyer, the Buyer agrees to provide all liability and physical damage insurance. It is further agreed that if on delivery and testing, any defects should develop, the Company shall be given reasonable time to correct changes. Guarantee of the chassis is subject to the guarantee of the chassis manufacturer. *NOTE: upon final inspection at the factory for pick-up or delivery, the Buyer will need to supply a Certificate of Insurance and full payment prior to release of the vehicle, unless prior arrangements for vehicle's release have been made.

TITLE:

The Apparatus shall always be the property of the Company until it is delivered to the Buyer pursuant to the terms of this agreement. The Company shall bear the sole responsibility and risk for destruction, loss or damage to the apparatus, or any portion of the Apparatus, through the date and time it is delivered to the Buyer. The Company shall deliver good and merchantable title to the Apparatus at the time it is delivered to the Buyer. The Buyer shall bear the sole responsibility and risk for destruction, loss or damage to the Apparatus upon the date and time it takes delivery of the Apparatus.

PIGGY BACK ORDERS:

The Company, at its sole discretion, will allow the terms of the contract to be extended to both the Buyer, as well as to other Municipal, State, or Federal agencies for similar unit(s). The Company will allow tag on / additional orders for up to three (3) years from the date of contract execution. To facilitate pricing, the Company will quote the original price plus manufacturer's price increases or Producer's Price Index (PPI) whichever is greater as it applies to either Fire Apparatus and/ or commercial heavy truck industries.

MISCELLANEOUS PROVISIONS:

This agreement shall be construed in accordance with the laws of the State of South Dakota. The parties agree that any litigation arising from or in connection with any dispute between the parties under this agreement shall be venue in South Dakota. The parties agree that this agreement bears a rational relationship to the State of South Dakota, and they consent to the personal jurisdiction of such state and further consent and stipulate to venue in the above described court.

The amount in this proposal shall remain firm for a period of 30 days from the date of same.

Respectfully submitted,

Dealer: General Fire Apparatus
Sales Rep: Brenden Feist
12/8/23

Buyer:

We accept the above proposal and enter into contract with signature below.

Title: _____

Title: _____

Date

After company receipt of this document signed by the Buyer, the document will be reviewed and upon approval, countersigned by the Company thereby putting the document in force.

Rosenbauer South Dakota, LLC

Title: _____

Date

www.rosenbaueramerica.com

info@rosenbaueramerica.com

ROSENBAUER SOUTH DAKOTA, LLC.
100 THIRD STREET
P.O. BOX 57
LYONS, SOUTH DAKOTA 57041
P: 605.543.5591

ROSENBAUER MINNESOTA, LLC.
5181 260TH STREET
P.O. BOX 549
WYOMING, MINNESOTA 55092
P: 651.462.1000

ROSENBAUER MOTORS, LLC.
5190 260TH STREET
P.O. BOX 549
WYOMING, MINNESOTA 55092
P: 651.462.1000

ROSENBAUER AERIALS, LLC.
870 SOUTH BROAD STREET
FREMONT, NEBRASKA 68025
P: 402.721.7622



APPENDIX C CHANGE ORDER POLICY

This change order policy is intended to reflect the increased cost of changes which result in delayed deliveries, confused paperwork, poor production flow and increased potential of trucks being built to incorrect specifications. With your cooperation, changes can be kept to a minimum which means we will be able to reduce lead times, increase production and maintain costs which will benefit all of us.

Our objective is accurate, high quality and on-time deliveries exceeding our customer expectations.

Changes any time after the order is received may delay the quoted delivery date. Significant design or component changes will have the largest impact on the schedule and quoted delivery date. Changes that occur later in the process will also have the largest impact on the schedule and quoted delivery date.

All time fences are referenced to contract execution date if not otherwise stated.

Change Window #1

All changes will be priced at standard pricing and specials will be priced through our normal process. Significant changes made to the vehicle during this time period may result in a delivery extension.

RBM Chassis 0-60 days
RBA Aerial 0-60 days
Rosenbauer Body 0-60 days

Change Window #2

All changes are subject to a 25% mark-up. All changes are subject to factory review and may be denied due to engineering or lead time issues.

RBM Chassis 61-75 days
RBA Aerial 61-75 days
Rosenbauer Body 61-120 days

Change Window #3

All changes are subject to a 50% mark-up, and 50% restocking fee on deleted items. All changes are subject to factory review and may be denied due to engineering or lead time issues. No major components can be changed at this time; major components are considered engine, transmission, axles, suspension, cab, frame (wheelbase), seats, water pump and water tank.

RBM Chassis 76-120 days
RBA Aerial 76-120 days
Rosenbauer Body 121-180 days

Change Window #4

Changes are not recommended at this time. Any changes requested will be priced on a time and material basis. Any changes requested, and that are quoted to the customer, must be approved by the customer within three days or they will not be valid.

RBM Chassis After 120 days
RBA Aerial After 120 days
Rosenbauer Body After 180 days

**Note: Any late change orders that are factory driven will be done at cost and no additional mark up or penalties will apply.*

SURCHARGE NOTICE

COVID-19 has caused extreme volatility in the global manufacturing supply chain. Inflationary pressures continue including raw materials, purchased parts, direct labor, and other firetruck components. In the event your truck order is affected by a surcharge, Rosenbauer America will provide an updated price quote. At that time, you have the option to continue with your truck purchase including the surcharge.

BUYER INITIALS: _____

www.rosenbaueramerica.com

info@rosenbaueramerica.com

ROSENBAUER SOUTH DAKOTA, LLC.
100 THIRD STREET
P.O. BOX 57
LYONS, SOUTH DAKOTA 57041
P: 605.543.5591

ROSENBAUER MINNESOTA, LLC.
5181 260TH STREET
P.O. BOX 549
WYOMING, MINNESOTA 55092
P: 651.462.1000

ROSENBAUER MOTORS, LLC.
5190 260TH STREET
P.O. BOX 549
WYOMING, MINNESOTA 55092
P: 651.462.1000

ROSENBAUER AERIALS, LLC.
870 SOUTH BROAD STREET
FREMONT, NEBRASKA 68025
P: 402.721.7622

East County Fire and Rescue
Camas, Washington

Account # 101117

Sourcewell Contact

If this is your organization and you need assistance, please contact:

Duff Erholtz

Email: duff.erholtz@sourcewell-mn.gov

Is this your organization?

Great news—your organization is already a Sourcewell participating agency! Using the account number provided on this page, you can immediately utilize Sourcewell awarded contracts by providing this number to the supplier you wish to purchase from.

Update your organization’s information

Add a contact for your organization

Need help?

Contact our dedicated Client Relations Team at service@sourcewell-mn.gov or 877-585-9706.



About

Careers

Compliance & Legal

Contact

News

Terms & Conditions

Privacy Policy

Accessibility

All Solutions →

Minnesota-Only Solutions →

Supplier Resources →



QUOTATION

General Fire Apparatus

East County Fire & Rescue
600 NE 267th Avenue
Camas, Washington 98607

General Fire Apparatus-PNWEE
3924 East Trent Avenue
Spokane, Washington 99202
509-242-2710

Quote No: 10616-0004
12/08/2023

PR 12/8/23

Page 1

PART NO	S	DESCRIPTION	QTY
== Rosenbauer Commander - 901.023 09/01/23 ==			
00-00-0120		-- CONFIGURATION ID: 2021B-XXXXX	1
03-00-0101		-- Certification - NFPA	1
08-09-0100		-- Cab Paint Warranty Five Years	1
08-09-0104		-- Cab Structural Warranty Ten Years	1
08-09-0105		-- Transmission Warranty Allison Five Years	1
08-09-0106		-- Engine Warranty Cummins Five Years	1
08-09-0107		-- Frame Warranty Lifetime	1
08-09-0109		-- Front Axle Warranty Hendrickson	1
08-09-010A		-- Rear Axle Warranty Meritor - 5 Year	1
08-09-0110		-- Warranty - Cab and Chassis One Year	1
08-09-0301		-- Cab Test Information Static Load Seat Test	1
08-09-0302		-- Cab Test Information Crash Test ECE-29	1
08-09-0303		-- Cab Test Information SAE J2420; J2422	1
08-09-0304		-- Cab Test Information Roof Crush, Side & Frontal Impact	1
08-09-0501		-- Operation & Parts List Manuals (2) Sets, USB Drive	1
08-09-0503		-- Engine & Transmission Operation Manuals (1) Set	1
08-09-0510		-- Engine Service Manual Cummins ISL/ISX (1) Set	1
08-09-0520		-- Transmission Service Manual Allison 3000EVS / 4000EVS (1) Set	1
08-09-0530		-- As Built Wiring w/Plumbing Diagram (1) Set	1
08-09-0540		-- On Board USB Manual Storage	1
08-80-0200		-- DOT KIT	1
VEHICLE TYPE			
03-00-0124		Pumper	1
03-00-0143		-- Additional Crossmembers RSD bodies	1
CAB			
03-00-0708		60" Cab Length 8" Roof	1
03-04-0004		-- Cab Drip Rail Extension	1
03-05-6200		-- Interior Cabinet, Center, Forward Facing, Floor Mounted, With Roll Up Door	1
03-05-9000		-- Compartment Shelf	2
05-01-1826		-- Forward Facing Compartment Interior Finish Match Interior Cab Coating	1
08-00-0718		-- Compartment Light, Wall, ROM, V3 LED Track Light, (1) Each	1
Compartmentt			
03-05-6004		-- === No Rear Engine Tunnel Compartments - PTS ===	1
03-05-6006		-- === No Upper Rear Wall Compartments - PTS ===	1
CAB STEPS			
03-06-0002		-- Stainless Steel	1

PART NO	S	DESCRIPTION	QTY
03-06-0015		-- Steps w/Grip Strut Lower, Treadplate Middle	1
CAB DOORS			
03-06-1015		-- Cab Entry Doors	1
03-06-1025		-- Full Length Cab Entry Doors	1
03-06-0021		-- Step Trim Kickplate, Treadplate	1
03-06-1500		-- No Lower Door Kick Panel (No Overlay)	1
03-06-1100		-- Cab Door Hardware Chrome (4)	1
03-06-1120		-- Cab Door Locks Manual	1
03-06-1140		-- Interior 1-Piece Door Panel Type SST	1
03-06-1225		-- Chevron, Reflective, Interior Cab Door - Scotchlite Red/Yellow	1
04-05-0112		-- Interior Handle Front Door Grab Handles - Red Powder Coat	1
04-05-0152		-- Interior Grab Handle Rear Door Chicago Style 34" Red Powder Coat	1
04-05-0182		-- Additional Grab Handles, "A" Pillar	1
CAB GLASS			
03-08-0014		-- Heated Windshield One Piece - COMMANDER	1
		SHOP NOTE: Will be switched in Vista on VMUX trucks.	
03-08-0102		-- Windshield Wiper System Single Motor (2) Wipers - 3D Grille	1
08-01-0346		-- Heated Windshield Activate Rocker Switch Driver Panel	1
03-08-0115		-- Window Driver w/Manual Regulator	1
03-08-0117		-- Window Officer w/Manual Regulator	1
03-08-0200		-- Window Driver Crew Door - Manual Regulator	1
03-08-0240		-- Window Officer Crew Door - Manual Regulator	1
03-08-0300		-- Window Side Middle Driver Fixed 15.5W" x 21.5"H	1
03-08-0350		-- Window Side Middle Officer Fixed 15.5"W x 21.5"H	1
CAB INTERIOR AND TRIM			
04-01-0152		-- === 8 Raised Cab 60" Interior Trim ===	1
03-09-7024		-- Cab Insulation Interior Ceiling 60/8"	1
03-09-8015		-- Cab Insulation Engine Tunnel	1
03-09-8017		-- Cab Insulation Underbody, 54" & 60" Cab	1
03-09-8020		-- Cab Insulation Cab Damping	1
04-01-1010		-- Interior Trim Color Gray, 60" - 8 Roof	1
04-01-1110		-- Interior Trim Color Gray Rear Wall 8" Roof	1
04-01-3099		-- ==== No Rear Wall Pac Trac - Mounted Full Width=====	1
04-02-1002		-- Suspended Throttle and Brake Pedals	1
04-02-1105		-- Interior Floor Covering Color Black, 60"	1
04-02-1702		-- Interior Trim Sun Visor Tinted	1
CAB DASH AND ENGINE TUNNEL - 60" LONG			
04-03-1052		-- Cab Dash & Engine Tunnel Alum Dash - Tunnel Mount HVAC	1
04-03-1010		-- Cab Dash & Engine Tunnel Coating Gray Polyurethane	1
04-03-1208		-- Flat Mounting Plate - Engine Tunnel, Aluminum Dash, Long Tunnel, Tunnel Mount HV	1
04-04-1360		-- Cup Holders	1
08-01-0144		-- Instrumentation Panel Inlay - Powder Coat Black	1
05-01-1055		-- Cab Coating Interior Gray Polyurethane	1
CAB EXTERIOR - 60"			
04-09-0205		-- Cab Exterior Trim Rear Wall Diamond Plate, 8" Roof	1
CAB HEADER - HEAT AND AC			
03-08-4000		Cab Header / Heating and AC	1
05-02-0020		-- Heating w/ Air Conditioning, Doghouse Mounted, 12V DC	1
05-01-6010		-- Cab Paint A/C Condenser on Roof	1
05-02-0048		-- Heater Hose - Rubber	1

PART NO	S	DESCRIPTION	QTY
05-02-0051		-- Heater Hose Insulation - Chassis & up to Cab SHOP NOTE: The Heater Hoses on the Chassis and up to and under the Cab shall be insulated	1
05-02-0054		-- Advanced Wiring Rear Crew Controls	1
05-02-0200		-- A/C Condenser Location Roof Mounted Mid Center	1
08-02-0126		-- Heating & Cooling Controls	1
SEATS			
03-09-0001		-- Seats Inc	1
03-09-0906		-- Seat Material Endurance Vinyl	1
03-09-0920		-- Seat Logo Rosenbauer	1
03-09-0100		-- Seat Color Gray/Red Seat Belt	1
03-09-01X3		-- Seat Driver 911 Seats Inc XL 10-Way Electric ABTS	1
03-09-000B		-- Dual Retractor Seat Belt - Seats Inc	1
03-09-0121		-- Seat Back Non-SCBA	1
03-09-02X3		-- Seat Mounting Driver Electric XL - Seats Inc	1
03-09-3010		-- Driver Seat Box Storage Compartment	1
03-09-3237		-- Seat Box Driver & Officer Storage Access Doors (2) Driver/Officer Vented	1
03-09-024D		-- Seat Officer 911 XL Seats Inc 6-Way Electric ABTS	1
03-09-000B		-- Dual Retractor Seat Belt - Seats Inc	1
03-09-0126		-- Seat Back SCBA IMMI Smart Dock	1
03-09-02X8		-- Seat Mounting Officer Electric XL Seats Inc	1
03-09-3020		-- Officer Seat Box Storage Compartment	1
03-09-033A		-- Two (2) Outboard Rear Facing Seats - XL	1
03-09-035B		-- Seat Crew Rear Facing Outer 911 Seats Inc XL Flip-Up ABTS SHOP NOTE: Belt Orientation shall pull from outboard shoulder to inboard hip	2
03-09-000B		-- Dual Retractor Seat Belt - Seats Inc	2
03-09-0126		-- Seat Back SCBA IMMI Smart Dock	2
03-09-038A		-- Seat Mounting Rear Facing Outer - XL Seats Inc.	2
03-09-0409		-- NO SEAT(S) OR SEAT BOX - Full Length Rear Wall Kick Plate	1
03-09-0826		-- Theater Seat - 911 Seats Inc. - Black - Driver & Officer FFO SHOP NOTE: NOT AVAILABLE WITH REAR WALL CUTOUT OR BUSTLE BACK RollTek is not available on Theater Seats Theater seats are not available on 70" and 78" cabs with side rear windows.	1
GRAB HANDLES			
04-05-1900		-- Exterior Grab Handles 18" Aluminum	1
04-05-1910		-- Exterior Grab Handles Bare Aluminum	1
04-05-0200		-- Exterior Grab Handles Aluminum with Stanchions 18"	4
CAB FRONT FASCIA			
04-08-0010		==== Traditional Front with Rectangular Headlamp Bezels ====	1
04-08-0140		-- Front Grille, 3D Stainless Steel SST	1
04-08-0022		-- Wing Light Bezel - Stainless Steel	1
04-08-0090		-- Logo, Rosenbauer, Grille Mount	1
04-08-0125		-- Front Grille Inlay, Black Honeycomb w/ Stainless Steel Bars	1

PART NO	S	DESCRIPTION	QTY
FLUID CHECKS & FILLS			
06-03-2023		-- Fluid Checks & Fills at Grille, Commander - X12	1
08-00-050C		-- Headlights, LED, Quad, with Rectangular Bezel - HiViz	1
08-00-0520		-- DRL & Wig Wag, Alternating Headlights - 12V DC	1
08-01-0342		-- Alternating Headlights Switch in Driver Console	1
08-00-0540		-- Headlight Location - Upper Bucket	1
SHOP NOTE:			
104 OS, 105 OS, and 104 DS, 105 DS			
08-00-0623		-- Front Turn Signals Whelen M6 LED (2) w/ Clear Lens	1
08-00-0630		-- Turn Signal Located Below Headlights	1
SHOP NOTE:			
106 OS & DS			
08-00-0608		-- Front Marker Lamps Face Mounted LED (Center 3 Lightings, 2 Corner)	1
08-00-061C		-- Side Marker Light LED - Chrome (2)	1
08-01-0303		-- Headlight & Marker Light Activated Rocker Switch Driver Panel	1
04-08-0151		Cab Fender SS	1
04-09-0300		Logo, Commander, Cab Sides	1
04-10-0351		Mud Flaps Front	1
CAB TILT			
05-00-0221		Cab Tilt System - Heavy Duty w/ Manual Back Up	1
05-00-0021		-- Cab Tilt Limit Switch	1
05-00-0045		-- Cab Tilt Lock Down Indicator	1
05-00-0100		-- Cab Tilt Control Receptacle Temp	1
REARVIEW MIRRORS			
05-00-5005		Bus Style Mirrors	1
05-00-7000		-- Ramco Bus, 17" Driver (Door Mnt), 17" Officer (Door Mnt), Lower Convex, Chrome	1
08-01-0821		-- Rearview Mirror Remote & Heat Switch Driver Panel	1
EXTERIOR CAB PAINT			
05-01-5010		Cab Paint Exterior Single Color	1
05-01-5021		-- Cab Paint Lower / Primary	1
SHOP NOTE:			
Paint Code:			
Paint Color:			
05-01-6051		-- Cab Undercoating	1
05-01-7000		-- Paint Spray Out	1
FRONT AXLE			
07-05-010B		Front Axle Hendrickson SteerTek 20000#	1
07-05-0120		-- Front Wheel Bearing Lube Oil	1
07-05-0272		-- Front Suspension Hendrickson Parabolic Spring 20K	1
07-05-0345		-- Power Steering Gear TRW TAS 85 w/Assist- 20K and up - X12 Steertek Axle	1
07-06-0420		-- Chassis Alignment	1
07-07-0186		-- (2) Steer Tires 385/65R 22.5 Bridgestone R244 "L" 19,840#	1
07-06-0436		-- Counter Acting Balancing Beads	2
07-07-0710		-- (2) Front Wheels Accuride 22.5 x 12.25 Steel - 23,000#	1
07-07-0902		-- Wheel Paint Primary/Lower Cab Color	1
07-08-0201		-- Front Brakes S-Cam Drum 16.5" x 6"	1
STEERING WHEEL / COLUMN			

PART NO	S	DESCRIPTION	QTY
07-05-0314		4 Spoke Steering Wheel Tilt/Telescopic 18"	1
		REAR AXLE	
07-06-0102		Rear Axle, Single, 27000# Meritor RS-25-160	1
07-06-0251		-- Rear Suspension Reyco 79KB Spring 27000# Conventional RS-25-160	1
07-08-0251		-- Rear Brakes S-Cam Drum 16.5" x 7"	1
07-06-0300		-- Rear Shock Absorbers	1
07-07-0345		-- (4) Rear Tires 12R 22.5 Bridgestone M799 "H"	1
07-06-0436		-- Counter Acting Balancing Beads	4
07-07-0751		-- (4) Rear Wheels Accuride 22.5 x 8.25 Steel	1
07-07-0902		-- Wheel Paint Primary/Lower Cab Color	1
07-07-0610		-- Valve Stem Extension - Single Axle	1
07-07-0994		-- Vehicle Top Speed 65 mph	1
07-08-0102		-- Auto Traction Control w/ ABS Single Axle	1
		SHOP NOTE: w/ air manifold	
07-05-0500		-- Mud/Snow Switch	1
		SHOP NOTE: Switch will be in Vista on V-Mux Trucks	
07-08-0189		-- Air Tank Brackets - Hot Dipped Galvanized	1
07-08-0302		-- Park Brake Rear w/Supplemental Front	1
08-02-0130		-- Park Brake Control Driver Dash	1
07-08-0410		-- Wabco System Saver 1200	1
07-08-0501		-- Auxiliary Air Reservoir 1200 Cu In	1
07-08-0551		-- Moisture Ejectors Manual	1
07-08-0570		-- Air Supply Lines Nylon	1
07-08-0601		-- Air Inlet Connection	1
07-08-0650		-- Plumbing Air Inlet Connection	1
07-08-06SF		-- Air Inlet Location Driver's Front Stepwell	1
07-08-0725		-- Air Horn Reservoir (1) 1200 Cu In	1
		FRAME	
07-09-001B		Frame Double Channel 35" Frame Width	1
07-09-0035		-- Wheelbase Range 190" - 199"	1
07-09-0071		-- Rear Overhang	1
07-09-0130		-- Frame Paint Powder Coat Black	1
		BUMPER	
10-04-0420		-- Front Bumpers, 4000, 2-Rib SST 12"H, S/S Wings	1
10-05-4212		-- Front Bumper, 2-Rib SST 12"H, T/P Apron, SST Wings, 12" Extension	1
10-04-2720		-- Hosewell Compartment, Center Bumper	1
10-04-3150		-- Aluminum T/P Door, Flat Style, Front Bumper Compartment	1
08-00-0719		-- Compartment LED Strip Light, (1) Each Compartment (approx 30")	1
08-00-071B		-- Compartment Light, Mounting Unistrut	1
55-06-1100		-- Compartment Light, Door Switch, Auto, Ea	1
10-04-3460		-- Gas Shock, Bumper Compartment Door	1
10-04-2940		-- Turtle Tile Grating, One (1) Bumper Compartment	1
10-05-9270		Tow Eyes 3" Painted Below - Rearward (pair)	1
		ENGINE	
06-00-0050		-- Engine Placement	1
06-00-1630		-- Engine, Cummins X 12, Base Spec, 2021 - Commander	1
		SHOP NOTE: CHANGE POWER STEERING TO CORRECT OPTION FOR X12	

PART NO	S	DESCRIPTION	QTY
NO GVWR OVER 77,000# W/O ENGINEERING APPROVAL			
06-00-0052		-- Cummins X12 & X15 Surcharge	1
06-00-1632		-- 500HP Cummins X12 - 2021	1
06-02-1121		-- Fan Clutch - X12	1
06-04-3000		-- Fan Clutch Programming - Standard	1
06-02-1526		-- Auxiliary Engine Brake Compression Brake (JAKE)	1
08-01-0204		-- Auxiliary Engine Brake Control On/Off & Low/Med/High Switch	1
Driver Panel			
06-02-2006		-- AC Compressor - X-12	1
06-03-1010		-- Engine High Idle Speed 1250 RPM	1
06-03-1025		-- Engine High Idle Control Manual & Automatic w/o Load Mng	1
06-05-3022		-- Engine Air Intake Filtration and Restriction X-12, Commander	1
06-06-3750		-- Engine Exhaust System One Piece Officer Side, X12, 2021	1
06-06-4006		-- DEF Tank - Commander	1
06-06-4100		-- DEF Tank Access Fill Door	1
06-08-0100		-- Engine Exhaust Acc Temp Mitigation	1
06-08-0200		-- Engine Exhaust Wrap	1
08-02-0140		-- DPF Control Regeneration Switch & Inhibit Switch Covered	1
08-09-0179		-- Cummins 10 year Extended Warranty - Major Components	1
06-04-2104		-- Engine Cooling System - X12 - Commander	1
06-04-4011		-- Coolant Valve Shut Off Valve w/Connection - For Additional Heater -	1
X-12			
06-05-1010		-- Engine Pump Heat Exchanger X-12 - Commander	1
TRANSMISSION			
07-01-0102		-- Transmission Allison 4000 EVS	1
07-01-0500		-- Transmission Fluid - Standard	1
07-02-0006		-- Transmission 6th GEN Push Button Key Pad	1
07-02-0013		-- Transmission 1 o'clock PTO	1
07-02-0052		-- Transmission Mode Programming 5th Startup/5th Mode	1
07-02-0066		-- Transmission Feature Programming I/O Package 198/Pumper	1
07-02-0253		-- Driveline Spicer 1810 HD	1
FUEL SYSTEMS			
07-04-0108		-- Fuel Filter/Water Separator Cummins FS1065	1
07-04-0310		-- Fuel Tank 50 Gal/189 Liter, Dual Fill	1
07-04-0216		-- Fuel Lines Aramid Braid	1
07-04-0225		-- Fuel Shutoff Valve (2) at Filter	1
07-04-0230		-- Fuel Cooler Rearward of Battery Box	1
ALTERNATORS			
08-00-0403		-- Alternator Delco Remy 275 Amp	1
ELECTRICAL SYSTEM			
08-00-0101		Electrical System 12V DC	1
04-04-1312		-- (1) Power Point & (1) USB/USB-C 12V Power Point - Driver's Side	1
04-04-1332		-- (1) Power Point & (1) USB/USB-C 12V Power Point - Officer's Side	1
04-04-1350		-- Officer Map Light	1
08-01-0034		-- 2 Position Battery Master - Driver's Kick Plate	1
08-01-0036		-- Ignition Switch	1
08-01-006N		-- Driver Switch Panels, Black	1
08-01-0075		-- Driver Panel / Controls & Switches - 12V DC Black	1
08-01-0240		-- Master Warning Switch on Driver Panel	1
ACCESSORY POWER DISTRIBUTION PANEL			
08-02-0176		-- Accessory Power Distribution Panel - 12 Position 40A Battery Direct W/ Ground	1
SHOP NOTE:			

PART NO	S	DESCRIPTION	QTY
		Please indicate location for Power Distribution panel(s):	
08-02-0512		-- Aux Pwr & Gnd Stud 40A Batt Direct SHOP NOTE: Please indicate location for Power Stud(s):	1
		ANTENNA	
08-03-0110		-- Communication Antenna Base Cab Roof - RBM Supplied SHOP NOTE: Shop Note Roof location. Location will be affected by Aerial Devices or Roof Mounted Accessories.	2
08-03-0230		-- Antenna Cable Routing Under Driver Front Seat	2
		LOAD MANAGER VEHICLE DATA RECORDER - SEAT BELT WARNING	
08-02-0612		-- Class 1 VDR/Seat Belt Warn	1
		ELECTRICAL ACCESSORIES	
08-01-001A		-- Commander Analog Gauge Aluminum Dash Black	1
08-01-0010		-- Instrumentation Standard Gauge Panel	1
		BATTERIES	
08-00-0340		6 Battery System	1
08-00-0322		-- Batteries (6) Group 31	1
08-00-023A		-- Battery Box Driver/Officer Side Hot dipped Galvanized Steel w/Covers -	1
		6 Battery	
08-00-0248		-- Battery Cables (6)	1
08-00-0251		-- Battery Jumper Studs Front Driver Lower Step	1
08-01-0040		-- Power & Ground Stud 40A Battery Direct / 15A Ignition	1
		LED LIGHTS - CHASSIS CAB	
08-00-072D		-- Ground Lights LED Whelen 3SC0CDRCR	4
08-01-0751		-- Ground Lights Activation with Park Brake	4
		STEP LIGHTS	
08-00-0735		-- Cab Step Lights LED (1 Per Door)	4
08-01-0753		-- Step Lights Activated Respective Side	4
		INTERIOR DOOR WARNING LIGHTS DOOR JAMB WARNING LIGHTS ENGINE COMPARTMENT LIGHTS	
08-00-0783		-- Engine Compartment Work Light LED (2)	1
		INTERIOR LIGHTING	
08-00-0796		-- Standard Dome Light Activation	1
08-00-0791		-- Interior Overhead LED Lighting - Red/Clear	1
		CORNERING - MARKER LIGHTS CAB SPOTLIGHTS	
08-00-3526		Splt, GoLight 20214, LED, Wired Remote, Black, On Cab Roof - Officer Side	1
08-94-0351		-- Go-Light Mount Officer Side - 8-11"	1
08-00-3524		Splt, GoLight 20214, LED, Wired Remote, Black, On Cab Roof - Driver Side	1
08-94-0341		-- Go-Light Mount Driver Side - 8-11"	1
		HANDHELD FLASHLIGHTS	
52-08-1225		-- Hand Light, Vulcan, With LED, w/ 12V Charger, p/n 44451	4
52-08-2300		-- Hand Light Install Location, Cab, Define	1
52-08-2310		-- Flashlight Install Engine Tunnel	1
		DOOR OPEN / HAZARD WARNING LIGHT INDICATOR SYSTEMS	
08-00-4090		Dr Open/Hazard Wrn Lt, Flash, Whelen 3SR00FRR LED Rnd (Do Not Move Appar	1

PART NO	S	DESCRIPTION	QTY
08-00-4103		Door Open Alarm	1
		CHASSIS WARNING LIGHTING - EQUIPMENT	
		WATER TANK GAUGES	
		AIR HORNS AND CONTROLS	
50-41-7100		-- Air Horns Two (2) 24" Round Hadley E-Tone	1
50-41-8140		-- Air Horn Location Two (2) Recess Mounted, Outboard, 1 Each Side	1
50-43-1000		-- Air Horn Controls	1
50-43-2500		-- Air Horn Control, Dual Lanyard Pull Cord	1
		ANTENNAS - RADIOS - HEADSETS - FIRE RADIOS	
		SURFACE MOUNT SCENE LIGHTS - 12 VOLT - CAB	
54-15-5900		-- Scene Light - Front / Cab Brow	1
51-16-5017		-- Scene Light, Fire Tech, FT-MB-27-FT-B, 30" Light Bar Mount, Black	1
54-15-6002		-- Scene Light Switch, Front Scene Lights, Cab Switch Panel	1
54-15-5908		-- Scene Light - Cab Left Side	1
54-15-4804		-- Scene Light, FireTech, Guardian, FT-GSM, Surface Mount	1
54-15-6400		-- Scene Light Switch , Left Scene Lights, Cab Switch Panel	1
54-15-5912		-- Scene Light - Cab Right Side	1
54-15-4804		-- Scene Light, FireTech, Guardian, FT-GSM, Surface Mount	1
54-15-6500		-- Scene Light Switch , Right Scene Lights, Cab Switch Panel	1
		ELECTRONIC SIREN - SPEAKERS - Q's - BELL	
56-01-1700		-- Siren, Electronic, Whelen 295HFS2	1
56-02-1600		-- Speaker, Fed Sig Dynamax, ES100C 100 Watt	1
56-02-1650		-- Speaker Grille, SST, "R"	1
56-03-1800		-- Speaker Location, To Be Determined by Body Mfg	1
		CAB LIGHTBARS - UPPER ZONE A	
57-02-1250		-- Light Bar, Whelen, Ultra Freedom IV, #F4N7QLED, LED, 72"	1
57-08-1100		-- Traffic Emitter, GTT Opticom, Lt Bar Mntd, 795H Low-Pro LED	1
		High-Priority, Prk B	
57-10-0600		-- Light Bar Control, with Master Warning Switch	1
		REAR FACING - UPPER WARNING LIGHTS - UPPER ZONE C	
58-70-1100		-- Warning Lights Upper Rear Provided on Body	1
		LOWER CAB WARNING LIGHTS	
		FRONT FACING - LOWER - CAB WARNING LIGHTS ZONE A	
58-03-6300		-- Warning Lights, Whelen, Upper Wing, (2) M6 LED	1
57-20-1200		-- Warn Light, Driver, Whelen, M6, Red LED, Color Lens, Ea	1
57-20-1201		-- Warn Light, Officer, Whelen, M6, Red LED, Color Lens, Ea	1
58-01-2140		-- Flange, Chrome, Warning Light, Whelen, M6, Ea	2
58-03-7300		-- Warning Lights, Whelen, Inboard Headlight, (2) M6 LED	1
57-20-1200		-- Warn Light, Driver, Whelen, M6, Red LED, Color Lens, Ea	1
57-20-1201		-- Warn Light, Officer, Whelen, M6, Red LED, Color Lens, Ea	1
58-01-2140		-- Flange, Chrome, Warning Light, Whelen, M6, Ea	2
58-09-2000		-- Warning Lights, Whelen, Intersection, (2) M6 LED	1
57-20-1200		-- Warn Light, Driver, Whelen, M6, Red LED, Color Lens, Ea	1
57-20-1201		-- Warn Light, Officer, Whelen, M6, Red LED, Color Lens, Ea	1
58-01-2140		-- Flange, Chrome, Warning Light, Whelen, M6, Ea	2
		SIDE WARNING LIGHTS - LOWER ZONE B and ZONE D	
58-08-0008		-- Lower Zone B and D Light Provided with Body	1
		BACK UP ALARMS	

PART NO	S	DESCRIPTION	QTY
08-01-2030		Back Up Alarm, Preco-Matic 1059 CAPTUM SYSTEM HAAS Alert System	1
08-02-0770		-- HAAS Alert System, HA-5	1
08-02-0775		-- HAAS - 5 Year Subscription AERIAL INTERFACE REAR FACING CAMERAS SHORELINE	1

QUOTATION

General Fire Apparatus

East County Fire & Rescue
600 NE 267th Avenue
Camas, Washington 98607

General Fire Apparatus-PNWEE
3924 East Trent Avenue
Spokane, Washington 99202
509-242-2710

Quote No: 10617-0006
12/08/2023

Page 1

PART NO	S	DESCRIPTION	QTY
		== Pumper/Tanker Bid Prep Forms - 901.023 09/01/23 ==	
00-00-0120		-- CONFIGURATION ID: 2021B-XXXXX	1
00-00-1100	S	Information Request Form (Factory Required)	1
00-00-1300		Fire Department Name	1
00-00-1499		Overall Height Restriction, NONE	1
00-00-1509		Overall Length Restriction, NONE	1
00-00-1519		Overall Width Restriction, NONE	1
00-00-1529		Wheelbase Restriction, NONE	1
00-00-1539		Angle of Approach, NFPA Minimum, 8 Degrees	1
00-00-1549		Angle of Departure, NFPA Minimum, 8 Degrees	1
		NFPA Equipment Allowances	
00-00-1610		NFPA Pumper Equipment Allowance 2500#	1
00-00-1799			1
00-00-3220		Contract Change Notice	1
00-12-1100		Financial Stability Response	1
01-06-0500		Calculated Center of Gravity	1
01-07-0062		-- Technical Drawings, Representative Drawings (4-View)(Left/Right/Rear/Front)	1
01-07-1100		Change Orders	1
02-02-0100		Pre-Construction Conference At Fire Dept.	1
02-02-0300	S	One (1) Final Inspection Trip; 2-FD People	1
02-03-0500		ISO Compliance	1
02-03-0204		Single Source Response, Commander Chassis, Rosenbauer	1
01-08-0150		Company History, Rosenbauer America	1
02-10-4000		Delivery (1001 to 1250 miles)	1
02-13-5020		Demonstration (Dealer Supplied)	1
02-13-5030		Delivery	1
02-13-7200		Body Manufacturer Service & Support Requirements	1
02-13-7300		Local Sales and Service Vehicle Support	1
02-13-7400		Toll Free Service Number	1
		== Pumper/Tanker Warranties - 901.023 09/01/23 ==	
01-16-0150		-- Warranty, Apparatus, Body Warranty, 1 Year	1
01-19-0250		-- Warranty, Body, Aluminum, 5 Years	1
01-19-2800		-- Warranty, Subframe, Lifetime Galvanized	1
01-20-0200		-- Warranty, Paint, PPG, 5 Years	1
01-21-0150		-- Warranty, Lettering and Striping, 1 Year	1
01-17-0700		-- Pump Warranty, Waterous, 7 Years	1
01-17-1050		-- Plmbg Warranty, Stainless Steel, 10 Years	1
01-18-0250		-- Warranty, Foam Tank, UPF	1
01-18-0450		-- Warranty, Water Tank, UPF	1
01-33-5150		-- Manuals, Electrical, As Built Body, 1 Set Printed w/Digital Copy	1

PART NO	S	DESCRIPTION	QTY
01-33-3710		-- In Process Photos	1
01-33-3810		-- Manuals, Body, Complete, Customized, Operation & Familiarization	1
02-90-0500		Chassis, Commander Custom	1
		== Use Drop Down to Add RBM Chassis - 901.023 09/01/23 ==	
		== Pumper/Tanker-DC Electrical Sys ROSENBAUER ONLY - 901.023 09/01/23 ==	
		EMERGENCY LIGHTING PACKAGES - ROSENBAUER	
		CAB LIGHTBARS - UPPER ZONE A	
57-01-0900		-- Light Bar, Chassis Supplied	1
		REAR FACING - UPPER WARNING LIGHTS - UPPER ZONE C	
58-71-1820		-- Warning Lights, Whelen, Upper Rear Body (2) S-LED Rotary L31 P/N L31*F	1
57-20-8100		-- Warn Light, Driver, Whelen, L31 LED Rotator Red Color Lens, Ea	1
57-20-8103		-- Warn Light, Officer, Whelen, L31 LED Rotator Amber Color Lens, Ea	1
58-74-5100		-- Stanchions, Rear Warning Light, Cast Alum	1
		LOWER WARNING LIGHTS	
		FRONT FACING - LOWER - CAB WARNING LIGHTS ZONE A	
58-00-0700		-- Lower Cab Warning Provided on Chassis	1
		SIDE WARNING LIGHTS - LOWER ZONE B and ZONE D	
58-13-3002		-- Front Intersection Lights Provided on Chassis	1
		SIDE FACING - LOWER - MID BODY WARNING LIGHTS	
58-26-2400		-- Warning Lights, Whelen, Lower Mid Body (2) M2 LED, in Rub Rail	1
		SHOP NOTE:	
		Will only fit in EXT rub rail WITHOUT bezel	
57-20-1000		-- Warn Light, Driver, Whelen, M2, Red LED, Color Lens, Ea	1
57-20-1001		-- Warn Light, Officer, Whelen, M2, Red LED, Color Lens, Ea	1
		SIDE FACING LOWER REAR CORNER WARNING LIGHTS	
58-36-2400		-- Warning Lights, Whelen, Lower Rear Side (2) M2 LED, in Rub Rail	1
		SHOP NOTE:	
		Will only fit in EXT rub rail WITHOUT bezel	
57-20-1000		-- Warn Light, Driver, Whelen, M2, Red LED, Color Lens, Ea	1
57-20-1001		-- Warn Light, Officer, Whelen, M2, Red LED, Color Lens, Ea	1
		REAR FACING - LOWER WARNING LIGHTS - LOWER ZONE C	
58-81-2000		-- Warning Lights, Whelen, Lower Rear Body (2) M6 LED	1
57-20-1200		-- Warn Light, Driver, Whelen, M6, Red LED, Color Lens, Ea	1
57-20-1201		-- Warn Light, Officer, Whelen, M6, Red LED, Color Lens, Ea	1
		12 VOLT ELECTRICAL INSTALLATION - PUMPERS/TANKERS	
50-02-1000		Electrical Base, Standard, W/Load Management	1
50-05-1510		-- Electrical Junction Box, Weather Resistant	1
50-10-1750		-- Load Manager, KUSS, Load Manager 2	1
		12 VOLT POWER SOURCES	
		DOME-CABINET-INTERIOR-ENGINE-PUMP LIGHTS	
51-05-7312		Light, Pump Compt, LED, AMDOR H20, (1) (approx 40")	1
51-05-9100		-- Light Swtch , Pump Panel	1
		EMEREC - MOBILE OPERATION MANAGEMENT	
		BACK UP ALARMS AND CAMERAS	
52-01-1100		Back Up Alarm, w/Chassis	1
		ANTENNAS - RADIOS - HEADSETS - FIRE RADIOS	
		MARKER AND DOT REQUIRED LIGHTS	
53-01-1200		Marker Lts, LED, DOT Requirements	1

PART NO	S	DESCRIPTION	QTY
53-02-1200		License Plate Bracket, SST w/ LED Light, Rear	1
53-03-0065		Whelen Rear DOT LED Lighting Package M6	1
53-03-2750		-- Tail/Brake Lights, Whelen, LED, M62BTT (Pair)	1
53-04-2750		-- Turn Signals, Whelen, LED w/ Arrow, M62T (Pair)	1
53-06-3550		-- Backup Lights, Whelen, LED, M62BU (Pair)	1
53-07-1210		-- (4) Light Bezel, Tail Lights, Whelen M6 (Pair), ABS Chrome	1
53-05-1802		Turn Signals, Mid Body, LED Marker Light TechNiq S17-AA2G0-1 (Pair)	1
GROUND LIGHTS			
54-01-1220		-- Ground Lights, Front Bumper, LED, Whelen 3SC0CDCR, Pair	1
54-03-1220		-- Ground Lights, Pump Panel, LED, Pr Whelen 3SC0CDCR	1
54-03-1620		-- Ground Lights, Rear Step, LED, Whelen 3SC0CDCR, Pair	1
54-04-1999		-- Light Switch , Ground Lights w/ Park Brake	1
STEP - WALKWAY - DECK LIGHTS			
54-10-1450		Step Light, Rear Tailboard, LED, Ea	2
54-11-2100		Light Switch , Step/Walkway Lights Wired Park Brake Switch	1
54-12-1918		Deck Lights, Rear Of Hosebed	1
54-12-1320		-- Deck Lights, Code 3, LED, 1-Spot #CW2450 & 1-Flood #CW2451, Black	1
54-12-3010		-- Deck Light Switch , Wired Park Brake Switch	1
TELESCOPING LIGHTS - BROW LIGHTS - 12 VOLT			
51-20-3200		-- Mounting Location, Rear Of Custom Cab	2
51-16-5097		-- TeleLight, FireTech, FT-SL-GESM-SW Black	2
51-15-2100		-- Teelight Pole, SM, Bottom Raise (#530)	2
51-20-4220		-- Light Switch, Remote Location, Pump Panel	2
51-20-5000		-- Hazard Switch, Telescopic Light	2
SURFACE MOUNT SCENE LIGHTS - 12 VOLT			
54-15-5924		-- Scene Light - Body Left Side	1
54-15-4804		-- Scene Light, FireTech, Guardian, FT-GSM, Surface Mount	1
54-15-5928		-- Scene Light - Body Right Side	1
54-15-4804		-- Scene Light, FireTech, Guardian, FT-GSM, Surface Mount	1
54-15-1470		-- SceneWarn Light, Mounting Plate, Painted	1
54-15-5932		-- Scene Light - Rear Body	2
54-15-4804		-- Scene Light, FireTech, Guardian, FT-GSM, Surface Mount	2
54-15-6600		-- Scene Light Switch , Rear Scene Lights, Cab Switch Panel	2
54-15-6700		-- Scene Light Switch , Rear Scene Lights, Auto w/ Reverse	1
DOOR OPEN / HAZARD WARNING LIGHT INDICATOR SYSTEMS			
55-11-1100		Door Open/Hazard Warning Light, w/Chassis	1
TRAFFIC CONTROL DEVICES			
MISCELLANEOUS WARNING LIGHTS			
== RBM Chassis Modifications - ROSENBAUER ONLY - 901.023 09/01/23			
==			
CHASSIS MODIFICATIONS			
PLACARDS and LABELING			
10-02-1100		-- Label, Data, Fluid Levels	1
10-02-1200		-- Label, Data, Height x Length, Weight	1
10-02-1300		-- Label, Data, "No Ride" Rr Step	1
10-02-2100		-- Label, Indicating Number of Seats	1
10-02-2500		-- Label, "Caution: Do Not Wear Helmet While Seated"	1
FRAME PREP AND MODIFICATIONS			
10-03-6000		-- Tow Plates (2), Rear Frame Rail, Under Step	1
80-43-2400		-- Painting, Tow Plates, Black	1
WHEEL TRIM AND COVERS			
10-06-1110		-- Wheel Trim, SST Hub/Lug Covers, Front/Rear, Single Axle	1
10-06-1600		-- Tire Pressure Indicator, Single Axle, Commercial, RWTG1235	1

PART NO	S	DESCRIPTION	QTY
EXHAUST SYSTEMS			
10-07-0100		-- Exhaust, Horizontal Supplied With Chassis	1
MUD FLAPS			
10-08-2100		-- Mud Flaps, Rear Wheels, Black, w/ Body	1
CHASSIS ELECTRICAL SYSTEMS			
CHASSIS AIR BRAKE SYSTEMS			
== Midship Pumper/Tanker Pump & Plumbing - 901.023 09/01/23 ==			
MIDSHIP SPLIT-SHAFT PUMPS			
20-02-3200		-- Pump, Darley, LDM, 1 Stage, Midship SHOP NOTE: All Pump Manufactures recommend that their Pumps are drained after every use and be stored dry. End user is responsible to follow this recommendation.	1
20-02-3130		-- Pump Flow Rtnng, Darley, LDM, 1750 GPM SHOP NOTE: All Pump Manufactures recommend that their Pumps are drained after every use and be stored dry. End user is responsible to follow this recommendation.	1
22-03-1600		-- Intk, Ungated, 6", LH Side	1
22-40-7900		-- Adptr, LW Alum, 30 Deg, 6"F x 5" Storz	1
22-41-7200		-- Cap, 5" Storz, LW Alum, Lckng, w/Chain or Cable	1
22-03-2600		-- Intk, Ungated, 6", RH Side	1
22-40-7900		-- Adptr, LW Alum, 30 Deg, 6"F x 5" Storz	1
22-41-7200		-- Cap, 5" Storz, LW Alum, Lckng, w/Chain or Cable	1
20-05-2500		-- Pump Seal, Mech, Darley LDM	1
20-05-3100		-- Pump Shift, Darley, Elec/Pneumatic, Midship	1
20-05-5100		-- Pump Primer, Darley, 12V Elec, Mnl Pull Cntrl	1
20-05-5900		-- Pump Dschg Manifold, Darley, Check Vlv	1
27-10-4550		-- Pressure Gvrnr, Class 1, TPG+, w/Bdy #119650	1
STAINLESS STEEL PUMP PLUMBING			
21-00-0090		-- Pump Panel Approval Drawing	1
21-00-2000		-- Screens/Anodes, Pump	1
21-00-3300		-- Piping, SST - 1250 GPM & Up	1
21-01-0300		-- Pump Drain, Master, Manifold, Hand Whl Type	1
21-01-7300		-- Unpainted, Pump & Piping	1
21-01-8100		-- Threads, National Hose (NST)	1
22-51-5210		-- Tank-To-Pump, Water Tank, 3" Vlv/4" Piping, Midship, Pmpr/Tnkr	1
22-50-0100		-- Single Tank to Pump Control - Pump Operator's Panel	1
24-62-1300		-- Vlv Mfger, AKR, 8000, (3")	1
22-55-4012		-- Intk Vlv Cntrl, Pull Rod, 1/4 Turn, AKR - IC	1
23-02-1300		-- Tank Fill/Cooling Line, Water Tank, 2"	1
24-62-1200		-- Vlv Mfger, AKR, 8000, (2")	1
22-55-4012		-- Intk Vlv Cntrl, Pull Rod, 1/4 Turn, AKR - IC	1
20-30-3100		-- Pump Instln, Midship Split-Shaft, By Bdy Bldr	1
PUMP INTAKE RELIEF AND COOLING			
20-31-3600		Dump-Relief Vlv, Suction Side, TFT A18	1
20-31-4100		Pump Cooler, Bypass-To-Tank, 3/8"	1
20-31-5100		Heat Exchanger, Engine, Hook-Up Only	1
PUMP TESTING			
20-31-1000		-- Fire Pump Testing - Pumpers/Tankers	1
20-31-1100		-- Pump Test, Pumper, UL	1
20-31-1500		-- Pump Test, Label	1
INTAKES			

PART NO	S	DESCRIPTION	QTY
22-12-1100		Intk, Aux, Gtd, 2-1/2", NST, Left Side	1
21-01-2502		-- Drain/Bleeder, IC Lift-Up, Mnl 1/4 Turn - Spec Only	1
22-41-1100		-- Plug, 2-1/2", Chrome Rocker Lug, w/Chain	1
24-62-1250		-- Vlv Mfger, AKR, 8000, (2-1/2")	1
22-55-4050		-- Intk Vlv Cntrl, AKR, Mnl Swing Type-Adjacent	1
22-12-3100		Intk, Aux, Gtd, 2-1/2", NST, Right Side	1
21-01-2502		-- Drain/Bleeder, IC Lift-Up, Mnl 1/4 Turn - Spec Only	1
22-41-1100		-- Plug, 2-1/2", Chrome Rocker Lug, w/Chain	1
24-62-1250		-- Vlv Mfger, AKR, 8000, (2-1/2")	1
22-55-4050		-- Intk Vlv Cntrl, AKR, Mnl Swing Type-Adjacent	1
22-13-3100		Intk, Aux, Gtd, 2-1/2", NST, Rear Right Side	1
21-01-2502		-- Drain/Bleeder, IC Lift-Up, Mnl 1/4 Turn - Spec Only	1
22-41-1100		-- Plug, 2-1/2", Chrome Rocker Lug, w/Chain	1
24-62-1250		-- Vlv Mfger, AKR, 8000, (2-1/2")	1
22-55-4012		-- Intk Vlv Cntrl, Pull Rod, 1/4 Turn, AKR - IC	1
BUMPER DISCHARGES			
23-05-3200		-- Dschg, 2" x 1-1/2" Front Center Bumper, Swivel, NST Brass Swivel	1
21-01-2200		-- Drain/Bleeder, Class 1, Automatic	1
23-05-9200		-- Hose Connection, Abv Frnt Bmpr, Swivel	1
24-61-1200		-- Vlv Mfger, AKR, 8000, (2")	1
24-53-0020		-- Dschg Vlv Cntrl, Pull Rod, 1/4 Turn, SM, AKR - IC w/Gauge	1
27-02-1500		-- Gauge, Dschg, IC, 2-1/2" (0-400 PSI), WF	1
CROSSLAY DISCHARGES			
23-06-2400		-- Crosslay Dschgs, (4) 1-1/2", Over Pump Panel, NST w/dividers	1
21-00-4000		-- 200-ft of 1-3/4-in Hose	1
21-01-2502		-- Drain/Bleeder, IC Lift-Up, Mnl 1/4 Turn - Spec Only	4
24-61-1200		-- Vlv Mfger, AKR, 8000, (2")	4
24-53-0020		-- Dschg Vlv Cntrl, Pull Rod, 1/4 Turn, SM, AKR - IC w/Gauge	4
27-02-1500		-- Gauge, Dschg, IC, 2-1/2" (0-400 PSI), WF	4
23-08-3300		-- Crosslay Cvr, Alum T/P, Sngl, W/Vinyl End Flaps (Non NFPA Walking Surface)	1
29-20-5600		-- Vinyl Cover, Color, RED	1
23-08-4100		-- Crosslay Rollers, "U" Shaped, Both Sides	1
23-08-5025		-- Crosslay Dschgs, Over Pump Panel, Sngl Stck	1
SPEEDLAY DISCHARGES			
LEFT SIDE DISCHARGES			
23-09-4100		Dschg, 2-1/2", Left Side, Pump Panel, NST	1
21-01-2502		-- Drain/Bleeder, IC Lift-Up, Mnl 1/4 Turn - Spec Only	1
24-02-1200		-- Elbow, 2-1/2"F x 2-1/2" NST M, Chrome	1
24-03-1400		-- Cap, 2-1/2", NST Chrome, Rocker Lug, w/Chain	1
24-61-1250		-- Vlv Mfger, AKR, 8000, (2-1/2")	1
24-53-0020		-- Dschg Vlv Cntrl, Pull Rod, 1/4 Turn, SM, AKR - IC w/Gauge	1
27-02-1500		-- Gauge, Dschg, IC, 2-1/2" (0-400 PSI), WF	1
RIGHT SIDE DISCHARGES			
23-10-4100		Dschg, 2-1/2", Right Side, Pump Panel, NST	1
21-01-2502		-- Drain/Bleeder, IC Lift-Up, Mnl 1/4 Turn - Spec Only	1
24-02-1200		-- Elbow, 2-1/2"F x 2-1/2" NST M, Chrome	1
24-03-1400		-- Cap, 2-1/2", NST Chrome, Rocker Lug, w/Chain	1
24-61-1250		-- Vlv Mfger, AKR, 8000, (2-1/2")	1
24-53-0020		-- Dschg Vlv Cntrl, Pull Rod, 1/4 Turn, SM, AKR - IC w/Gauge	1
27-02-1500		-- Gauge, Dschg, IC, 2-1/2" (0-400 PSI), WF	1
23-10-5200		Dschg, 3" x 4"NST, Right Side, Pump Panel, NST	1
21-01-2502		-- Drain/Bleeder, IC Lift-Up, Mnl 1/4 Turn - Spec Only	1

PART NO	S	DESCRIPTION	QTY
24-02-2600		-- Elbow, LW Alum, 5" Storz x 4"F	1
24-03-2200		-- Cap, LW Alum, 5" Storz, w/Cable	1
24-61-1300		-- Vlv Mfger, AKR, 8000, (3")	1
24-53-0300		-- Dschg Vlv Cntrl, Pull Rod, 1/4 Turn, SM, AKR Slow Close - IC w/Gauge	1
27-02-1500		-- Gauge, Dschg, IC, 2-1/2" (0-400 PSI), WF	1
CATWALK DISCHARGES and HOSEBEDS			
FRONT HOSEBED DISCHARGES - MIDSHIP and PTO			
REAR BODY DISCHARGES -- MIDSHIP and PTO			
23-13-3100		Dschg, 2-1/2", Left Rr, NST	1
21-01-2502		-- Drain/Bleeder, IC Lift-Up, Mnl 1/4 Turn - Spec Only	1
24-02-1200		-- Elbow, 2-1/2"F x 2-1/2" NST M, Chrome	1
24-03-1400		-- Cap, 2-1/2", NST Chrome, Rocker Lug, w/Chain	1
24-61-1250		-- Vlv Mfger, AKR, 8000, (2-1/2")	1
24-53-0020		-- Dschg Vlv Cntrl, Pull Rod, 1/4 Turn, SM, AKR - IC w/Gauge	1
27-02-1500		-- Gauge, Dschg, IC, 2-1/2" (0-400 PSI), WF	1
MONITOR DISCHARGES			
24-11-3200		Monitor Dschg, 3", Over Midship Pump Enclsr, NPT	1
21-01-2500		-- Drain/Bleeder, IC Lift-Up, Mnl 1/4 Turn	1
24-61-1300		-- Vlv Mfger, AKR, 8000, (3")	1
24-53-0300		-- Dschg Vlv Cntrl, Pull Rod, 1/4 Turn, SM, AKR Slow Close - IC w/Gauge	1
27-02-1500		-- Gauge, Dschg, IC, 2-1/2" (0-400 PSI), WF	1
24-14-1400		-- Mntr, TFT, CrossFire, XFC-62, Pkg (Top, Base, Nozzle, Tips, Xtnd-Gun)	1
24-14-1700		-- Nzzle, TFT M-R1250S-NJ	1
24-14-1800		-- Base Inlets, TFT XFH-2NJ Dual 2-1/2" NH	1
24-14-1910		-- Stream Shaper, TFT XF-SS10	1
24-14-2000		-- Quad Stack Tips, TFT MST-4NJ	1
24-14-2020		-- Storage Bracket TFT #XF-B	1
24-14-3000		-- Extenda Gun, TFT XG18VL-XL	1
HOSE REELS			
FOAM SYSTEMS and TANKS			
25-06-4200		-- Foam Sys, F/PRO 2002, Cls A/B, 5G/400P, 12V	1
25-20-1200		-- Foam Plmbg, Sngl Class A Tank, 1" Mnl Vlv	1
25-21-1500		-- Foam Tank, Intgrl Poly, 30 Gal, Class A	1
25-22-9300		-- Foam Tank, UPF	1
25-23-1000		-- Foam Tank Drain, 1" Gate Vlv, Under Tank	1
25-19-9000		-- Foam System, NFPA #1901, Install Standards	1
== Pumper/Tanker-Side Mount Pump Compt - 901.023 09/01/23 ==			
SIDE MOUNT PUMP ENCLOSURE			
26-02-2300		Pump Enc, Side Mt, Extrd Alum, 50-59"W, Crslys	1
SIDE MOUNT PUMP ENCLOSURE OPTIONS			
26-10-2100		Pump Enc Cmpt, SM, Dnng Over Pump, Open	1
PUMP ENCLOSURE STEPS and RUNNING BOARDS			
26-30-1100		Rng Brd, LH Pump Panel, Alum T/P, SM	1
26-30-1150		Rng Brd, RH Pump Panel, Alum T/P, SM	1
PUMP ENCLOSURE ACCESS DOORS OR PANELS			
26-31-1300		Pump Side Access Door, Upper RH, SST	1
26-31-4000		Frt Access Pump Panel, Alum T/P, Rmvbl, D-Ring Latches, Single Door	1
PUMP PANEL SURFACE -- MIDSHIP AND PTO			
26-35-3200		Pump Panel, SST, LH/RH, SM	1
26-35-1300		-- Pump Panel, Hngd, LH	1
26-35-1400		-- Pump Panel, Hngd, RH	1
PUMP ENCLOSURE HEATERS and HEAT PANS and GASKET			
26-50-3100		Heat Pan, Pump Enc, Midship, Slide Out Panel, Glvnzd Stl	1

PART NO	S	DESCRIPTION	QTY
26-50-4100		Gasket, Rubber, Pump Enc/Bdy Flex Joint	1
PUMP PANEL LABELING			
26-55-1100		Labels, Test Data and Safety Placards	1
26-55-2400		Labels, Innovative Controls Color Coded	1
LIGHTING OF PUMP PANEL AND ENCLOSURE			
26-56-1170		Pump Panel LED Lt, (1) AMDOR H20, LH (approx 40")	1
26-56-1270		Pump Panel LED Lt (1), AMDOR H20, RH (approx 40")	1
26-56-2000		Pump Panel Lt (1), Actuated w/Pump Engagement	1
MASTER PRESSURE GAUGES			
27-01-1500		-- Mstr Gauges, IC, 4" PSI, Pr	1
27-01-4100		Gauge, Test Taps	1
WATER TANK GAUGES			
27-35-4024		Water/Foam Gge, IC, 10-LED Wtr/Fm Dual Dsply , Pmp Pnl (Strght) 3030359-04	1
AIR EQUIPMENT for PUMP PANEL			
27-37-2000		Air Outlet, Pump Panel, Plug-in Connection, Left Side	1
PUMP PANEL RADIO EQUIPMENT			
27-38-1200		Radio Spkr, Fire, Pump Panel	1
PUMP PANEL HANDRAILS			
33-70-4200		Handrails, Pmpr, Side Pump Panel, Vert, 24", Pair == HLHD/HRHD Single Axle Pumper/Tanker - 901.023 09/01/23 ==	1
WATER TANKS			
25-26-1500		-- Water Tank, 1000 Gal, Pmpr/Tnkr , Poly	1
25-25-0060		-- Water Tank, "T" Tank	1
25-44-1300		-- Water Tank, Fill Tower, 10" x 10", <1500 Gals	1
25-42-1100		-- Water Tank, Base Specs, Poly	1
25-42-1200		-- Water Tank, Manufacturer, UPF, Poly	1
HOSEBED - HOSEBED COVERS - DIVIDERS - HOSE LOAD			
29-10-1000		Hosebed, Grating, Extrd Alum, <180" Long	1
29-10-5100		-- Hosebed, Strge Cpcty, 55 Cubic Feet, Minimum	1
29-10-5600		-- Hosebed, Strge Cpcty 2.5" DJ Hose (50-ft Lngth)	8
29-10-5700		-- Hosebed, Strge Cpcty 3" DJ Hose (50-ft Lngth)	40
29-10-8100		Hosebed, Divider, 1/4" Alum	4
26-37-1100	S	-- S.O.R./ Storage, Back Boards in Hosebed Two(2)	1
29-10-8300		-- Hosebed, Divider, Handhole Cutouts	4
29-10-8600		Alum Box Around Fill Towers	1
29-20-2000		Hosebed Cvr, Vinyl, <180" L, <74" W, Velcro	1
29-20-5600		-- Vinyl Cover, Color, RED	1
BODY CONSTRUCTION			
30-00-0299		Raw Material Surcharge - Single Axle	1
30-01-1900		Bdy Const - Rosenbauer FX - 3/16" Alum - SA Pmpr/Tnkr	1
30-01-2250		-- Electrolysis Corrosion Cntrl	1
30-02-2200		-- Smooth Alum Compt Floors	1
30-10-1100		-- Sub Frame, Hot-Dip Galv	1
30-10-1010		-- Sub Frame, Hot-Dip Galv (Design Notice)	1
31-01-1100		-- Bdy, Frmd Alum, Pmpr/Tnkr , Up to 144"	1
44-06-2200		-- Whl Well Panel, Alum Pntd, Sngl Axle - Alum	1
44-06-4300		-- Fenderette, Polished Stainless Steel SST	1
31-01-2137		102" OAW, 16-26" Half Dpth Both Sides, SA HL/HR	1
29-00-1200		-- Hosebed, Pmpr, <180" L, 68" Wide	1
32-03-0066		-- Cmpt Height, 66" High Left	1
32-03-1066		-- Cmpt Height, 66" High Right	1
32-04-1430		Hngd/Roll Up Combination, HL/HR	1

PART NO	S	DESCRIPTION	QTY
30-02-1100		-- Drs, Hngd Specs	1
30-02-1105		-- Dr Handle, Maltese Cross D-Ring, Hngd Drs	6
30-02-1140		-- Roll-Up Drs - Amdor	1
LEFT SIDE COMPARTMENTS			
32-05-1105		-- Ahd Rr Whls - Full Ht Comp't - Hnge Sgle Dr	1
44-40-1100		-- Vents, Compts, Louvers, Includes Filters (Ea)	1
45-01-1050		-- Shelving Tracks, (2) Unistrut, Alum	1
45-02-3100		-- Shelf, Adjust, Alum 3/16"	2
45-30-1300		-- Turtle Tile, Shelves/Trays, (each)	2
45-05-3100		-- Slide Tray, 250#, Alum 3/16"	1
45-30-1300		-- Turtle Tile, Shelves/Trays, (each)	1
45-30-1400		-- Turtle Tile, Compartment Floor	1
55-01-5114		-- Strip Light, LED Luma Bar, (2) Ea Compartment	1
55-06-1100		-- Compartment Light, Door Switch, Auto, Ea	1
32-05-1310		-- Upr Hgh Sde - Sgle Comp't - Hnge Lift Up	1
44-40-1100		-- Vents, Compts, Louvers, Includes Filters (Ea)	1
45-01-1050		-- Shelving Tracks, (2) Unistrut, Alum	1
45-30-1400		-- Turtle Tile, Compartment Floor	1
55-01-5114		-- Strip Light, LED Luma Bar, (2) Ea Compartment	1
55-06-1100		-- Compartment Light, Door Switch, Auto, Ea	1
32-05-1705		-- Bhnd Rr Whls - Full Ht Comp't - Hnge Sgle Dr	1
44-40-1100		-- Vents, Compts, Louvers, Includes Filters (Ea)	1
45-01-1050		-- Shelving Tracks, (2) Unistrut, Alum	1
45-02-3100		-- Shelf, Adjust, Alum 3/16"	2
45-30-1300		-- Turtle Tile, Shelves/Trays, (each)	2
45-30-1400		-- Turtle Tile, Compartment Floor	1
55-01-5114		-- Strip Light, LED Luma Bar, (2) Ea Compartment	1
55-06-1100		-- Compartment Light, Door Switch, Auto, Ea	1
RIGHT SIDE COMPARTMENTS			
32-06-1105		-- Ahd Rr Whls - Full Ht Comp't - Hnge Sgle Dr	1
44-40-1100		-- Vents, Compts, Louvers, Includes Filters (Ea)	1
45-01-1050		-- Shelving Tracks, (2) Unistrut, Alum	1
45-02-3100		-- Shelf, Adjust, Alum 3/16"	2
45-30-1300		-- Turtle Tile, Shelves/Trays, (each)	2
45-05-3100		-- Slide Tray, 250#, Alum 3/16"	1
45-30-1300		-- Turtle Tile, Shelves/Trays, (each)	1
45-30-1400		-- Turtle Tile, Compartment Floor	1
55-01-5114		-- Strip Light, LED Luma Bar, (2) Ea Compartment	1
55-06-1100		-- Compartment Light, Door Switch, Auto, Ea	1
32-06-1410		-- Upr Hgh Sde - Sngl Comp't - Hng Lift Up Dr	1
44-40-1100		-- Vents, Compts, Louvers, Includes Filters (Ea)	1
45-01-1050		-- Shelving Tracks, (2) Unistrut, Alum	1
45-30-1400		-- Turtle Tile, Compartment Floor	1
55-01-5114		-- Strip Light, LED Luma Bar, (2) Ea Compartment	1
55-06-1100		-- Compartment Light, Door Switch, Auto, Ea	1
32-06-1705		-- Bhnd Rr Whls - Full Ht Comp't - Hnge Sgle Dr	1
44-40-1100		-- Vents, Compts, Louvers, Includes Filters (Ea)	1
45-01-1050		-- Shelving Tracks, (2) Unistrut, Alum	1
45-05-3100		-- Slide Tray, 250#, Alum 3/16"	1
45-30-1300		-- Turtle Tile, Shelves/Trays, (each)	1
45-30-1400		-- Turtle Tile, Compartment Floor	1
55-01-5114		-- Strip Light, LED Luma Bar, (2) Ea Compartment	1
55-06-1100		-- Compartment Light, Door Switch, Auto, Ea	1

PART NO	S	DESCRIPTION	QTY
REAR COMPARTMENT			
33-60-1100		Rr Bdy, Flat Back	1
32-08-0110		-- Rr Cntr Comp't - Low Roll Up/Trans - Natural Finish	1
44-40-1100		-- Vents, Compts, Louvers, Includes Filters (Ea)	1
45-05-3100		-- Slide Tray, 250#, Alum 3/16"	1
45-30-1300		-- Turtle Tile, Shelves/Trays, (each)	1
45-30-1400		-- Turtle Tile, Compartment Floor	1
55-01-5114		-- Strip Light, LED Luma Bar, (2) Ea Compartment	1
55-06-1100		-- Compartment Light, Door Switch, Auto, Ea	1
33-61-1300		-- Rr Step, Pmpr-Tnkr Bdy, Bolt-On, 12"	1
COMPARTMENT STORAGE PROVISIONS			
EQUIPMENT - BODY MOUNTED			
90-02-1300		Ladder Mounting, Hydraulic Rack, End Mount, Passenger Side	1
90-02-0510		-- Controls, Mounting, Equipment Rack, Pump Panel	1
90-02-5300		Ladder Mounting, Folding Attic, External	1
90-03-0225		Ladders, Ground, Provided By Body Builder, SD	1
90-16-5460		Pike Pole Mounting, Aluminum Tube, Hydraulic Ladder Rack, Ea,	2
90-16-6115		Pike Pole Provided By, Body Builder SD	1
90-25-7750		Suction Hose Compt, Above Comp'ts, Driver Side Painted Smooth (Ea)	1
90-02-2920		-- Compartment Door, Smooth, With Chevron	1
== Pumper/Tanker-Common Body Parts - 901.023 09/01/23 ==			
FRONT BODY DESIGN - PUMPER/TANKER			
33-66-1160		-- Steps, Fldg, Frnt, Left Hand (4), Integral LED Lts	1
33-66-2100		-- Step, Fldg, Frnt, Right Hand, Integral LED Lts	1
33-70-3600		-- Handrails, Pmpr, Top of Bdy Sides, Frnt, 12", Pair	1
44-01-1450		-- Bdy Trim, Frnt Cmp't, Ht of Side Cmp'ts, Alum T/P	1
44-01-6020		-- Catwalks Top of Side Cmp'ts, Painted	1
REAR BODY DESIGN - PUMPER/TANKER			
44-01-4000		-- Bdy Trim, Entire Rr Bdy, Smooth for Chevron Stripe	1
44-01-5000		-- Polished Compt Top Welds	1
44-07-4200		-- Fuel Tank, Removable Access Panel	1
AUXILIARY REAR STEPS - PUMPER/TANKER			
33-62-4140		-- Steps, Fldg, Rear, Left Hand (3), Integral LED Lts	1
33-62-4240		-- Steps, Fldg, Rear, Right Hand (3), Integral LED Lts	1
33-62-5400		-- Step, Bltd, Treadplate, Rr Intermediate, 68"	1
HANDRAILS - PUMPER/TANKER			
33-70-1400		-- Handrails, Rr Step, Vert, 60", Pair	1
33-70-2200		-- Handrails, Pmpr, Below Hosebed, Horz, 60"	1
33-70-3600		-- Handrails, Pmpr, Top of Bdy Sides, Frnt, 12", Pair	1
RUB RAILS - PUMPER/TANKER BODY			
44-02-1100		-- Rub Rails, Lwr Bdy, Extrd Alum	1
44-02-2000		-- Rub Rails, Spacers, Nylon	1
WHEEL WELL PANEL - PROVISIONS			
44-11-5100		Whl Well Prvsns, Ahd of Whls Left Side	1
44-10-1600		-- Whl Well Compt, Sngl SCBA, Poly Tube, SST Dr, (Fire Shopp)	1
44-10-6000		-- Whl Well Compt, SCBA Compt Straps	1
44-11-5300		Wheel Well Provisions, Behind Wheels Left Side	1
44-07-1200		-- Fuel Fill Cap, LH Whl Well Panel-Open	1
44-10-4100		-- Whl Well Compt, Extngrshr, Brshd SST Dr	1
44-10-6000		-- Whl Well Compt, SCBA Compt Straps	1
44-11-5500		Whl Well Prvsns, Ahd of Whls Right Side	1
44-10-1600		-- Whl Well Compt, Sngl SCBA, Poly Tube, SST Dr, (Fire Shopp)	1
44-10-6000		-- Whl Well Compt, SCBA Compt Straps	1

PART NO	S	DESCRIPTION	QTY
44-11-5700		Whl Well Prvsns, Bhnd Whls Right Side	1
44-10-1600		-- Whl Well Cmpt, Sngl SCBA, Poly Tube, SST Dr, (Fire Shopp)	1
44-10-6000		-- Whl Well Cmpt, SCBA Cmpt Straps	1
ROOF COMPARTMENTS - LEFT SIDE ROOF COMPARTMENTS - RIGHT SIDE ROOF COMPARTMENTS - FRONT OF BODY ADDITIONAL ROOF STORAGE ACCESSORIES UNDERBODY COMPARTMENTS == Pumper/Tanker-AC Electrical System - 901.023 09/01/23 == 120/240 VOLT ELECTRICAL - PUMPER/TANKER			
60-17-0001			1
120 / 240 VOLT RECEPTACLES SHORELINE POWER			
60-26-1000		Receptacles Chassis Cab (Shoreline Wired)	2
60-25-9610		-- Shore Power Strip, 120V, 15 Amp, 4-Plug Strip Receptacle	2
60-30-5500		-- Receptacle Location, Inside Cab, Crew Area, Ea	2
60-26-1100		Receptacles (Shoreline Wired)	2
60-25-9610		-- Shore Power Strip, 120V, 15 Amp, 4-Plug Strip Receptacle	2
60-30-5500		-- Receptacle Location, Inside Cab, Crew Area, Ea	2
ELECTRIC CABLE REELS 120 / 240 VOLT FLOODLIGHTS 12-VOLT / 120-VOLT / 240-VOLT LIGHT TOWERS 120 VOLT FLUORESCENT LIGHTING == Pumper/Tanker-Equipment Systems - 901.023 09/01/23 == AIR SYSTEMS AIR REELS AND EQUIPMENT WINCHES HITCHES-TIE OFFS-RECEIVERS HYDRAULIC SYSTEMS == Pumper/Tanker - Single Axle - Pnt/Ltr/St - 901.023 09/01/23 == PAINT			
80-22-1504		Body Paint, Single Axle, Pumper/Tanker - Single Color	1
80-06-1100		-- Apparatus Color	1
SHOP NOTE: The apparatus shall be ____ in color.			
80-30-1200		Compt Finish, Spatter Coat, Up to 8 Compts	1
80-40-1100		Wheels, Aluminum, By the Chassis Manufacturer	1
80-42-1500		Body Paint, Touch Up, 2 oz. Bottle, One Color	1
80-44-1400		Undercoating, Body, Single Axle	1
LETTERING AND STRIPING			
80-50-2000		Lettering, 4" Scotchlite Reflect, Seventy-Five (75) Letters	1
80-70-2000		Stripe, Single Reflective, 6", "Z" Design	1
80-73-1100		-- Reflective Pin Stripe Black	1
80-75-1600		-- Reflective Stripe Material, White	1
80-72-1100		Stripe, Reflective 3M, Chevron Pattern Entire Rear Red/Yellow	1
80-79-1000		NFPA Standing / Walking Surfaces Yellow Safety Tape (NFPA 15.7.1.6)	1
== Pumper/Tanker - Loose Equipment - 901.023 09/01/23 == EQUIPMENT - LOOSE WHEEL CHOCKS			
90-01-5900		Wheel Chocks Pair Zico #SAC-44 Folding w/ Mounts	1
GROUND LADDERS			
90-03-3200		-- Ladder, Roof, Duo-Safety, 12' Aluminum 775-A	1

PART NO	S	DESCRIPTION	QTY
90-06-4700		-- Ladder, Extension, Duo-Safety, 28' Aluminum, 2 Section 1200-A	1
90-08-2600		-- Ladder, Attic, Duo-Safety, 10' Aluminum, Folding 585-A	1
PIKE POLES			
90-16-2600		-- Pike Pole, 8' Fiberglass, Round Handle	1
90-16-2800		-- Pike Pole, 10' Fiberglass, Round Handle	1
AXES AND MOUNTS			
SPANNER - STORZ - HYDRANT WRENCHES			
NFPA TOOLS - EQUIPMENT			
TOOL MOUNTING AND BRACKETS			
SCBA MOUNTING BRACKETS			
TARPS AND SALVAGE COVERS			
FIRE HOOKS UNLIMITED - FIRE HOOKS			
HARD SUCTION HOSES			
90-25-3100		-- Suction Hose, Flex, PVC, 6"x10'	1
90-25-6100		-- Suction Hose Couplings, Aluminum, LH FM x RLM	1
SUCTION HOSE STRAINERS - STRAINER MOUNTS			
90-26-1600		Suction Strainer, Barrel Type, 6", Kocheck #BS60	1
FOLDING TANKS			
FIRE EXTINGUISHERS - SYSTEMS AND SAFETY ITEMS			
FIRE HOSE			
NOZZLES			
MISCELLANEOUS HARDWARE - EQUIPMENT - TOOLS			
DEALER SUPPLIED EQUIPMENT			

Approximate Center of Gravity Calculated

City Name: 250 EAST COUNTY, WA

Chassis Vertical Center of Gravity From Ground		
Tilt Table		From Manufacture
Chassis Track Width-	0.00	41
Degree to Tip Over-	1.00	
Chassis CG (inches)-	0.00	

Ground to Top of Frame-	41
Rear Axle Track Width-	72

	Overall Height of Load	Top of Frame Rails to Bottom of Load	CG Above Frame	Weight	Vertical Moment (Inch Lbs)
Tank & Water (& Foam)- Lower	12	1.5	7.5	2277	17076.68182
Tank & Water (& Foam)- Upper	24.75	13.5	25.875	7284	188462.3502
Hose	31.50	40.00	55.75	1804	100573
Pump	18	10	19	3218	61142
Body	88.5	-17	27.25	3744	102024
Ground Ladders	28	13.5	27.5	131	3602.5
Chassis	See Above		0.00	19864.6	0
Personnel <small>(If 0 included in Chassis Weight)</small>	56	4	32	1000	32000
Equipment	63	-16.5	15	4954	74310
Aerial Device	See Drawing			0	0
	Total		13.08	44276.1	579190.532

CG Above Ground 54.08

Verticle Center Of Gravity
Height Compared To Track
Width 75.11%
(To Be Less Than 80%)

Horizontal Center of Gravity
(From Rear Axle) 76.60

Rosenbauer- South Dakota

DEPARTMENT: 250 EAST COUNTY, WA

Wheel Base	182
C A	122
Cab to Pump Compartment	3
Pump Compartment	52
Tank Length Lower	114
Tank Length Upper	136
Body Length	144
Total Tank Capacity	1030
Aerial Size	0



Percent of Weight to Front Axle		
Water (& Foam) Lower	Body	Pump
3.85%	-3.30%	51.10%
Water (& Foam) Upper	Aerial	Hose
-2.20%	NA	-2.75%

	TOTAL WT	FRONT WT	REAR WT
Water (& Foam) Lower	2,277	88	2,189
Water (& Foam) Upper	7,284	-160	7,444
Body	3,744	-123	3,867
Pump	3,218	1,644	1,574
Aerial	NA	0	0
Chassis	19,865	15,095	4,769
Miscellaneous Equipment	2,454	1,278	1,176
SUB TOTAL	38,841	17,822	21,019
NFPA 1901 Equipment Allowance	2,500	-133	2,633
Additional Equipment Allowance	0	0	0
NFPA Personnel Load 4	1,000	1,000	0
Hose Load	1,804	-50	1,854
Ground Ladders	131	-4	135
	0	0	0
TOTAL	44,276	18,635	25,641
		42.09%	57.91%

NOTE: Weights shown are approximate

<i>Proposed chassis information:</i>	Brand:	COMMANDER	Crew Doors:	4	GVWR
		2 Wheel Drive			
Axle Capacities:	Front:	20,000	Rear:	27,000	47,000
Estimated Chassis Weight: (includes +5% variance)	Front:	15095	Rear:	4769	

NOTE: Chassis weights MUST BE VERIFIED by the DEALER. Dealer will be responsible for confirming the axles are adequate for the proposed apparatus. 1000# extra capacity per axle is recommended.

- NOTES:
1. OVERALL HEIGHT IS IN LOADED CONDITION. UNLOADED HEIGHTS MAY BE 4" ABOVE HEIGHTS SHOWN.
 2. DO NOT SCALE DRAWING.
 3. ALL DIMENSIONS ARE APPROXIMATE AND SUBJECT TO ENGINEERING CHANGES.
 4. DRAWING MAY OR MAY NOT SHOW ALL ITEMS AS DESCRIBED IN THE WRITTEN DETAIL SPECIFICATIONS.
 5. INCLUSION OF AN ITEM ON THE DRAWING DOES NOT CONSTITUTE INCLUSION OF THAT ITEM WITH THE FINAL DELIVERED UNIT.
 6. THE EFFECTIVE DOOR OPENINGS WILL BE APPROX. 2" LESS THAN THE NOTED COMPARTMENT OPENING FOR ROLL UP DOORS AND UP TO APPROX. 4" LESS FOR HINGED DOORS

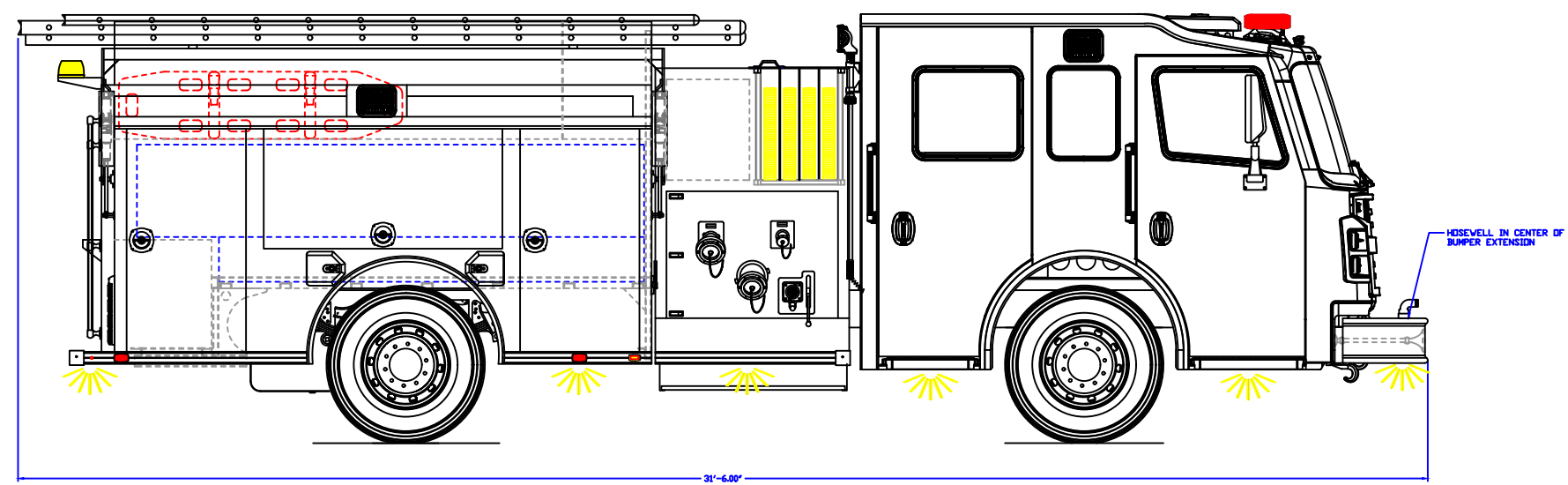
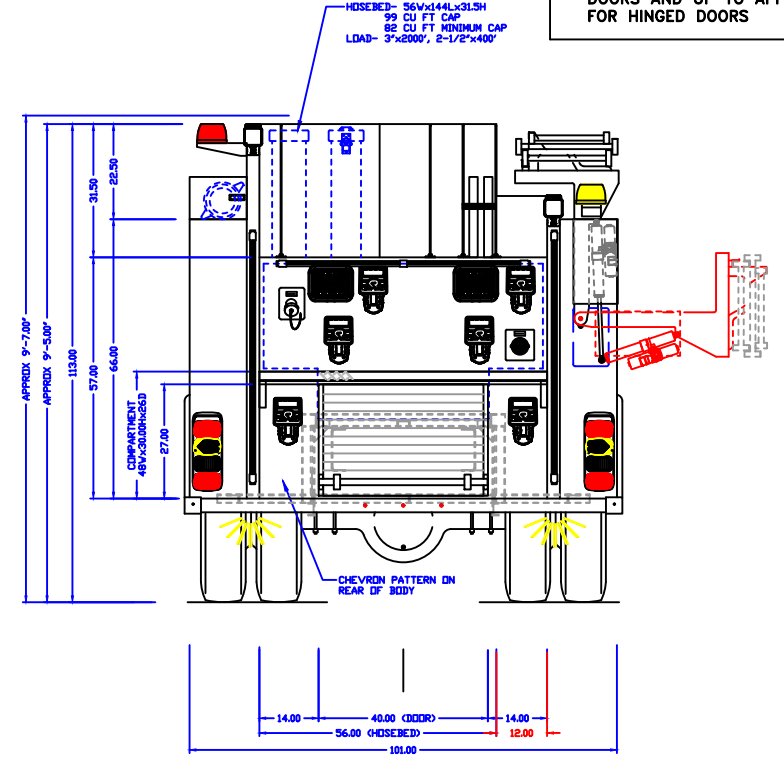
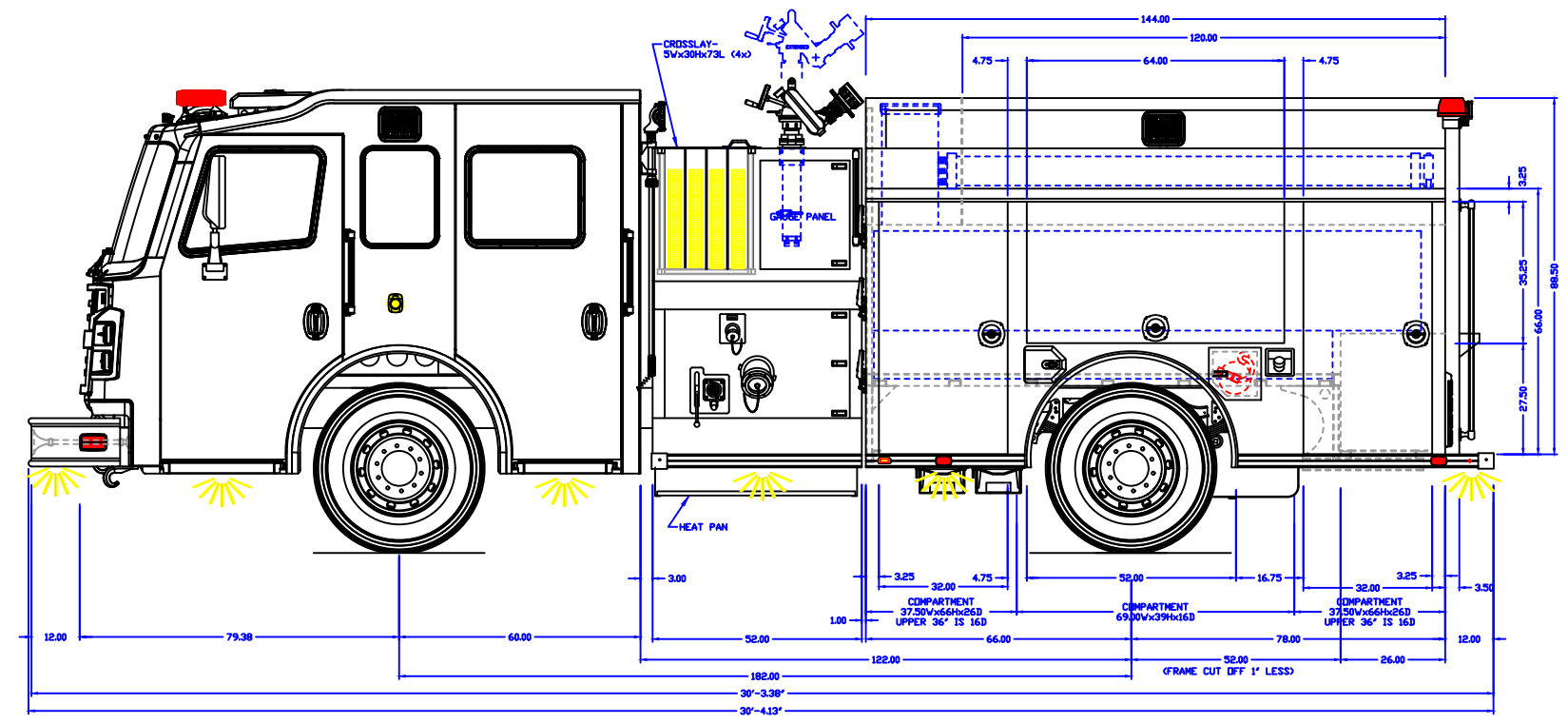
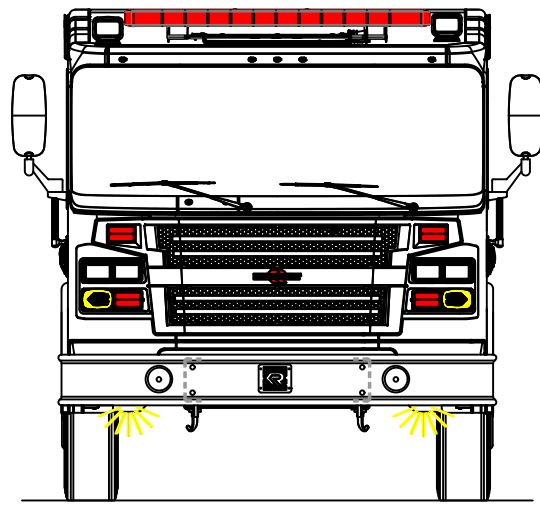

APPROVED BY:

CHASSIS:	COMMANDER 6008
PUMP:	DARLEY 1750 GPM
TANK:	POLY/1000/30(FOAM)
PANEL MATL:	STAINLESS STEEL
COMP INTERIOR:	DA SANDED

REVISID: - DATE: -
 DRAWN: WLM DATE: 09-20-23

PROPRIETARY AND CONFIDENTIAL
 THE INFORMATION CONTAINED IN THIS DRAWING IS THE SOLE PROPERTY OF ROSENBAUER. ANY REPRODUCTION IN PART OR AS A WHOLE WITHOUT THE WRITTEN PERMISSION OF ROSENBAUER IS PROHIBITED.

MAXIMUM HEIGHT	NONE
MAXIMUM LENGTH	NONE
BODY WIDTH	95"

EAST COUNTY FIRE AND RESCUE

ROSENBAUER FX 3/16"
 DRAWING NUMBER 250-D



East County Fire and Rescue

600 NE 267th Avenue Camas, WA 98607

(360) 834-4908 (phone)

(360) 835-8920 (fax)

www.ecfr.us



Resolution #339-12192023

A resolution providing for transfer of funds from the General Fund to the Grants Management Fund to meet our requirement of a 5% match for Assistance to Firefighters Grant (AFG) EMW-2022-FG-01031.

WHEREAS each of the district's funds is a separate fiscal entity and is established to conduct specific activities and attain objectives in accordance with statutes, laws, regulations, and restrictions or for specific purposes; and

WHEREAS A 5% match by the district is required for Assistance to Firefighters Grant (AFG) EMW-2022-FG-01031 for incident command training and source capture diesel exhaust extraction systems at Stations 91, 93, and 94.

NOW, THEREFORE, BE IT RESOLVED by the Board of Commissioners of East County Fire & Rescue as follows:

Transfer \$12,111.29 from the General Fund (6291) to the Grants Management Fund (6291-6) to meet our requirement of a 5% match.

ADOPTED at a Regular Meeting of the Board of Commissioners for East County Fire and Rescue December 19, 2023 with the following Commissioners being present and voting:

Martha Martin, Chairperson

Michael Taggart, Vice Chair

Sherry Petty, Commissioner

Steve Hofmaster, Commissioner

Joshua Seeds, Commissioner

Attest

Debbie Macias, District Secretary
Ed Hartin, Chief (Alternate)

Dec 2023 - East County Fire & Rescue

Sun	Mon	Tue	Wed	Thur	Fri	Sat
3 C SHIFT	4 A SHIFT	5 B SHIFT	6 C SHIFT	7 A SHIFT	8 B SHIFT	9 C SHIFT
	Events 10-Minute Training Stations 91 & 94	Events 10-Minute Training Stations 91 & 94 Allen working his Kelli OTEP 91 Commissioner Meetir Station 91	Events 10-Minute Training Stations 91 & 94 Strategic Planning Me Station 91 OTEP 91	Events OTEP 09:00 - 11:00 91 15:00 - 16:30 18:30 - 21:00	Events Tri Tech Heating - rep: 09:00 - 13:00 Station 91	Events Sorensen Attending E 09:00 - 13:00 Virtual
10 A SHIFT	11 B SHIFT	12 C SHIFT	13 A SHIFT	14 B SHIFT	15 C SHIFT	16 A SHIFT
	Events 10-Minute Training Stations 91 & 94	Events 10-Minute Training Stations 91 & 94 walkthrough for foam Tom Couch - Volunteer Conference Room Jayden Foster - Volun Conference Room	Events 10-Minute Training Stations 91 & 94			OTE Wed Dec 6, 2023 18:3
17 B SHIFT	18 C SHIFT	19 A SHIFT	20 B SHIFT	21 C SHIFT	22 A SHIFT	23 B SHIFT
	Events 10-Minute Training Stations 91 & 94	Events 10-Minute Training Stations 91 & 94 Commissioner Meetir Station 91	Events 10-Minute Training Stations 91 & 94			Wed Dec 6, 2023 21:0 91
24 C SHIFT	25 A SHIFT	26 B SHIFT	27 C SHIFT	28 A SHIFT	29 B SHIFT	30 C SHIFT
	Events 10-Minute Training Stations 91 & 94	Events 10-Minute Training Stations 91 & 94	Events 10-Minute Training Stations 91 & 94			
31 A SHIFT						

* Indicates time starts on following calendar day
 * Events and Time Off follow default Split Time of Day of 07:00